

PHILIPPINE ELECTRICAL CODE REVIEWER

I dedicate the accomplishment of this work to God, who has given me strength and enough wisdom to accomplish such task of summarizing and reviewing topics covered by PEC 2009. I also dedicate this work to my beloved mother, *Darlene Dumbrique*, the girl who has been there for me even through the hardest of times. And because of my love for her I put my best in every work I have to give in return to her love.

I dedicate this work as well to my family, relatives, friends, to all of the people who have helped me in financial provisions especially when I am still studying, to all who believed in me, motivated me, inspired me. Thank you. And this work is also for all the people that would read this that they may be blessed and be helped by this piece of work I have done during my review for Board Exam (September 2014) for them to gain knowledge and understanding. God bless!

-Andryn Jill D. Beltran

July, 21, 2014

Contact: roadtostar21@yahoo.com

Table of Contents

CHAPTER 1 – GENERAL	1
Definition of Terms	2
Permits and Inspection Certificates	6
Electrical Plans and Specifications	7
Requirements for Electrical Installations	9
CHAPTER 2 - WIRING AND PROTECTION	11
Use and Identification of Grounded Conductors	11
Branch Circuits	11
Branch Circuit Ratings	12
Feeders	14
Branch Circuit, Feeder, and Service Calculations.....	14
Outside Branch Circuits and Feeders	17
Open Conductor Spacing (Clearances) – Feeders and Conductors.....	18
Overhead Service	18
Services	20
Underground Service.....	21
Overcurrent Protection	24
Grounding and Bonding	25
Surge Arresters	29
Transient Voltage Surge Suppressor	29
Protection Against Lighting	30
CHAPTER 3 – WIRING METHODS AND MATERIALS	32
Approved Type of Wiring Method	32
Wiring Methods	32
Conductors for General Wiring	33
Cabinets, Cutout Boxes, and Meter Socket Enclosures	40
Outlet, Device, Pull, and Junction Boxes; Conduit Bodies; Fittings; and Handhole Enclosures	40
Armored Cable: Type AC	42
Integrated Gas Spacer Cable: Type IGS	42
Flat Cable Assemblies: Type FC.....	42

Flat Conductor Cable: Type FCC.....	43
Medium Voltage Cable: Type MV.....	43
Service Entrance Cable: Type SE and USE.....	44
Metal-Clad Cable: Type MC.....	44
Mineral-Insulated, Metal-Sheathed Cable: Type MI.....	45
Power and Control Tray Cable: Type TC.....	45
Nonmetallic-Sheathed Cable: Types NM, NMC, and NMS.....	46
Underground Feeder and Branch Circuit Cable: Type UF.....	47
Intermediate Metal Conduit: Type IMC.....	47
Rigid Metal Conduit: Type RMC.....	48
Rigid Nonmetallic Conduit: Type RNC.....	49
Flexible Metal Conduit: Type FMC.....	49
Liquidtight Flexible Metal Conduit: Type LFMC.....	50
High Density Polyethylene Conduit: Type HDPE Conduit.....	50
Nonmetallic Underground Conduit with Conductors: Type NUCC.....	51
Liquidtight Flexible Nonmetallic Conduit: Type LFNC.....	51
Electrical Metallic Tubing: Type EMT.....	52
Flexible Metallic Tubing: Type FMT.....	52
Electrical Nonmetallic Tubing: Type ENT.....	53
Auxiliary Gutters.....	53
Busways.....	54
Cablebus.....	54
Cellular Floor Raceways (Concrete and Metal).....	55
Wireways.....	55
Concealed Knob-and-Tube Wiring.....	55
Other Approved Wiring Methods by PEC.....	55

CHAPTER 4 – EQUIPMENT FOR GENERAL USE	56
Flexible Cord/Cable	56
Fixture Wires	56
Switches	57
Receptacles, Cord Connectors, and Attachment Plugs (CAPS).....	57
Switchboards and Panelboards.....	58
Industrial Control Panel	59
Luminaires (Lighting Fixtures), Lampholders, and Lamps	59
Appliances.....	60
Motors, Motor Circuits, and Controllers.....	60
Air-Conditioning and Refrigerating Equipment	67
Generators	67
Capacitors.....	69
Resistors and Reactors	69
Storage Batteries	70
CHAPTER 5 – SPECIAL OCCUPANCIES	71
Hazardous Locations	72
Materials Groups	72
Class I, Zone 0, 1, and 2 Locations	73
Zone 20, 21, and 22 Locations	74
Motor Fuel Dispensing Facilities	75
Health Care Facilities	75
Assembly Occupancies	78
Theaters, Audience Areas of Motion Picture and Television Studios, Performance Ares	79
Carnivals, Circuses, Fairs, and Similar Events	79
Motion Picture and Television Studios and Similar Locations.....	80
Motion Picture Projection Rooms.....	80
Mobile Homes, Manufactured Homes, and Mobile Parks	80
Recreational Vehicles and Recreational Vehicle Parks	82
Floating Building.....	83
Marinas and Boatyards.....	83

CHAPTER 6 – SPECIAL EQUIPMENT	84
Electric Signs and Outline Lightings	84
Cranes and Hoists	85
Elevators.....	86
Swimming Pools, Fountains, and Similar Locations	88
Solar Photovoltaic Systems.....	90
CHAPTER 7 – SPECIAL CONDITIONS.....	93
Emergency Systems	93
Legally Required Standby Systems	94
Optional Standby Systems	94
CHAPTER 8 – COMMUNICATION SYSTEMS	95
Communication Circuits	95
Radio and Television Equipment	95
APPENDIX	96
Types of NEMA Enclosures	
Standard FLC of Single Phase AC Motors	
Standard FLC of 3-Phase Synchronous Motors (Unity Power Factor)	
Standard FLC of 3-Phase Induction Motors	
Standard FLC of Single Phase Transformers	
Standard FLC of 3-Phase Transformers	
Standard Rating of Disconnects (Amperes)	
Standard Rating of Switchboards or Switchgears	
Standard Rating of Fuses and CB's (Amperes)	
Standard Rating of Busways or Busducts (Amperes)	
Standard Sizes of Gutters and Wireways	
Standard Sizes of Pull Boxes and Junction Boxes	
Trade Name, Operating Temperature and Type Letter of Different Wires and Conduits	

The P.E.C. 2009 consists of two (2) parts:

- ✓ **PART I**
 - Volume 1 - Consists of rules which regulate electrical installation done “inside” the building.
 - Volume 2 - Consists of rules which regulate electrical installation applied to “watercraft”.
- ✓ **PART II**
 - Consists of rules which regulate electrical installation done “outside” the building.

CHAPTER 1 - GENERAL

Purpose of P.E.C. 2009:

1. **Practical Safeguarding**
2. **Adequacy** - This *Code* contains provisions that are considered minimum requirements necessary for safety. Compliance therewith and proper maintenance will result in an installation that is essentially free from hazard but not necessarily efficient, convenient, or adequate for good service or future expansion.
3. **Intention** - This *Code* is intended for the exclusive use of licensed electrical practitioners (PEE, REE, and RME). This *Code* is not intended as a design specification nor an instruction manual for a non-licensed electrical practitioner, unless under the supervision of a licensed electrical practitioner.
4. **Relation to Other International Standards** - The requirements in this Code address the fundamental principles of protection for safety contained in Section 131 of International Electrotechnical Commission Standard 60364-1, *Electrical Installations of Buildings*.

Mandatory Rules, Permissive Rules, & Explanatory Material:

1. **Mandatory Rules** - Mandatory rules of this *Code* are those that identify actions that are specifically required or prohibited and are characterized by the use of the terms “*shall*” or “*shall not*”.
2. **Permissive Rules** - Permissive rules of this *Code* are those that identify actions that are allowed but not required, are normally used to describe options or alternative methods, and are characterized by the use of the terms “*shall be permitted*” or “*shall not be required*”.
3. **Explanatory Material** - Explanatory material, such as references to other standards, references to related sections of this Code, or information related to a *Code* rule, is included in this *Code* in the form of *fine print notes* (FPN). (FPN) are informational only and are not enforceable as requirements of this *Code*.

Coverage or Scope of PEC 2009

Covered-The installation of electrical conductors, equipment, and raceways; signaling and communications conductors, equipment, and raceways; and optical fiber cables and raceways installed.

1. Public and private buildings, including but not limited to residential, commercial, industrial, institutional, cultural, agricultural, agro-industrial, planned unit development and all other buildings or premises that may require practical safeguarding of persons and property from hazards arising from the use of electricity.
2. Electric generating plants
3. Industrial plants
4. Transformer stations
5. Permanent and temporary substations, etc.
6. Airfields
7. Railways switchyards
8. Yards, carnival, parks, parking and other lots
9. Quarries and mines
10. Watercraft
11. Dockyards
12. Trailers
13. Mobile homes and recreational vehicles
14. Offshore facilities

Not Covered - The following installations are not covered:

1. Railway rolling stock, aircraft, or automotive vehicles
2. Railways for generation, transformation, transmission, or distribution of power used exclusively for operation of rolling stock.

DEFINITIONS

Accessible (as applied to equipment) - Admitting close approach; not guarded by locked doors, elevation, or other effective means.

Accessible (as applied to wiring methods) - Capable of being removed or exposed without damaging the building structure or finish or not permanently closed in by the structure or finish of the building.

Accessible, Readily (Readily Accessible) - Capable of being reached quickly for operation, renewal, or inspections without requiring those to whom ready access is requisite to climb over or remove obstacles or to resort to portable ladders, and so forth.

Ampacity - The current, in amperes, that a conductor can carry continuously under the conditions of use without exceeding its temperature rating.

Appliance - Utilization equipment, generally other than industrial, that is normally built in standardized sizes or types and is installed or connected as a unit to perform one or more functions such as clothes washing, air conditioning, food mixing, deep frying, and so forth.

Approved - Acceptable to the authority having jurisdiction.

Askarel - A generic term for a group of nonflammable synthetic chlorinated hydrocarbons used as electrical insulating media. Askarels of various compositional types are used. Under arcing conditions, the gases produced, while consisting predominantly of noncombustible hydrogen chloride, can include varying amounts of combustible gases, depending on the askarel type.

Attachment Plug (Plug Cap) (Plug) - A device that, by insertion in a receptacle, establishes a connection between the conductors of the attached flexible cord and the conductors connected permanently to the receptacle.

Authority Having Jurisdiction (AHJ) - The organization, office, or individual responsible for approving equipment, materials, an installation, or a procedure.

Automatic - Self-acting, operating by its own mechanism when actuated by some impersonal influence, as, for example, a change in current, pressure, temperature, or mechanical configuration.

Bonding (Bonded) - The permanent joining of metallic parts to form an electrically conductive path that ensures electrical continuity and the capacity to conduct safely any current likely to be imposed.

Bonding Jumper - A reliable conductor to ensure the required electrical conductivity between metal parts required to be electrically connected.

Branch Circuit - a set of conductors that extends beyond the last overcurrent device protecting the circuit and the outlet(s).

Circuit Breaker - A device designed to open and close a circuit by non-automatic means and to open the circuit automatically on a predetermined overcurrent without damage to itself when properly applied within its rating.

Adjustable - Indicating that the circuit breaker can be set to trip at various values of current, time, or both, within a predetermined range.

Instantaneous Trip - No delay is purposely introduced in the tripping action of the circuit breaker.

Inverse Time - There is purposely introduced a delay in the tripping action of the circuit breaker, which delay decreases as the magnitude of the current increases.

Nonadjustable - It does not have any adjustment to alter the value of current at which it will trip or the time required for its operation.

Setting - The value of current, time, or both, at which an adjustable circuit breaker is set to trip.

Concealed - Rendered inaccessible by the structure or finish of the building. Wires in concealed raceways are considered concealed, even though they may become accessible by withdrawing them.

Conductor, Bare - A conductor having no covering or electrical insulation whatsoever.

Conduit Body - A separate portion of a conduit or tubing system that provides access through a removable cover(s) to the interior of the system at a junction of two or more sections of the system or at a terminal point of the system. Boxes such as FS and FD or larger cast or sheet metal boxes are not included.

Connector, Pressure (Solderless) - A device that establishes a connection between two or more conductors or between one or more conductors and a terminal by means of mechanical pressure and without the use of solder.

Continuous Load - A load where the maximum current is expected to continue for 3 hours or more.

Controller - A device or group of devices that serves to govern, in some predetermined manner, the electric power delivered to the apparatus to which it is connected.

Copper-Clad Aluminum Conductors - Conductors drawn from a copper-clad aluminum rod with the copper metallurgically bonded to an aluminum core. The copper forms a minimum of 10 percent of the cross-sectional area of a solid conductor or each strand of a stranded conductor.

Cutout Box - An enclosure designed for surface mounting that has swinging doors or covers secured directly to and telescoping with the walls of the box proper.

Dead Front - Without live parts exposed to a person on the operating side of the equipment.

Demand Factor - The ratio of the maximum demand of a system, or part of a system, to the total connected load of a system or the part of the system under consideration.

Disconnecting Means - A device, or group of devices, or other means by which the conductors of a circuit can be disconnected from their source of supply.

Dusttight - Constructed so that dust will not enter the enclosing case under specified test conditions.

Duty, Continuous - Operation at a substantially constant load for an indefinitely long time.

Duty, Intermittent - Operation for alternate intervals of (1) load and no load; or (2) load and rest; or (3) load, no load, and rest.

Duty, Periodic - Intermittent operation in which the load conditions are regularly recurrent.

Duty, Short-Time - Operation at a substantially constant load for a short and definite, specified time.

Duty, Varying - Operation at loads, and for intervals of time, may be subject to wide variation.

Enclosed - Surrounded by a case, housing, fence, or wall(s) that prevents persons from accidentally contacting energized parts.

Enclosure - The case or housing of apparatus, or the fence or walls surrounding an installation to prevent personnel from accidentally contacting energized parts or to protect the equipment from physical damage.

Energized - Electrically connected to a source of voltage.

Exposed (as applied to live parts) - Capable of being inadvertently touched or approached nearer than a safe distance by a person. It is applied to parts that are not suitably guarded, isolated, or insulated.

Exposed (as applied to wiring methods) - On or attached to the surface or behind panels designed to allow access.

Feeder - All circuit conductors between the service equipment, the source of a separately derived system, or other power supply source and the final branch-circuit overcurrent device.

Festoon Lighting - A string of outdoor lights that is suspended between two points.

Fitting - An accessory such as a locknut, bushing, or other part of a wiring system that is intended primarily to perform a mechanical rather than an electrical function.

Ground-Fault Circuit Interrupter (GFCI) - A device intended for the protection of personnel that functions to de-energize a circuit or portion thereof within an established period of time when a current to ground exceeds the values established for a Class A device.

Grounding Conductor - A conductor used to connect equipment or the grounded circuit of a wiring system to a grounding electrode or electrodes.

Grounding Conductor, Equipment - The conductor used to connect the non-current-carrying metal parts of equipment, raceways, and other enclosures to the system grounded conductor, the grounding electrode conductor, or both, at the service equipment or at the source of a separately derived system.

Grounding Electrode - A device that establishes an electrical connection to the earth.

Grounding Electrode Conductor - The conductor used to connect the grounding electrode(s) to the equipment grounding conductor, to the grounded conductor, or to both, at the service, at each building or structure where supplied by a feeder(s) or branch circuit(s), or at the source of a separately derived system.

Guarded- Covered, shielded, fenced, enclosed, or otherwise protected by means of suitable covers, casings, barriers, rails, screens, mats, or platforms to remove the likelihood of approach or contact by persons or objects to a point of danger.

Handhole Enclosure - An enclosure identified for use in underground systems, provided with an open or closed bottom, and sized to allow personnel to reach into, but not enter, for the purpose of installing, operating, or maintaining equipment or wiring or both.

Hoistway - Any shaftway, hatchway, well hole, or other vertical opening or space in which an elevator or dumbwaiter is designed to operate.

In Sight From (Within Sight From, Within Sight) - Where this Code specifies that one equipment shall be "in sight from," "within sight from," or "within sight," and so forth, of another equipment, the specified equipment is to be visible and not more than 15 m (50 ft) distant from the other.

Interrupting Rating - The highest current at rated voltage that a device is intended to interrupt under standard test conditions.

Live Parts - Conductor or conductive part intended to be energized in normal use.

Location, Damp - Locations protected from weather and not subject to saturation with water or other liquids but subject to moderate degrees of moisture. Examples of such locations include partially protected locations under canopies, marquees, roofed open porches, and like locations, and interior locations subject to moderate degrees of moisture, such as some basements, some barns, and some cold-storage warehouses.

Location, Dry - A location not normally subject to dampness or wetness. A location classified as dry may be temporarily subject to dampness or wetness, as in the case of a building under construction.

Location, Wet - Installations underground or in concrete slabs or masonry in direct contact with the earth; in locations subject to saturation with water or other liquids, such as vehicle washing areas; and in unprotected locations exposed to weather.

Luminaire - A complete lighting unit consisting of a lamp or lamps together with the parts designed to distribute the light, to position and protect the lamps and ballast (where applicable), and to connect the lamps to the power supply.

Multioutlet Assembly - A type of surface, flush, or freestanding raceway designed to hold conductors and receptacles, assembled in the field or at the factory.

Non-automatic - Action requiring personal intervention for its control. As applied to an electric controller, non-automatic control does not necessarily imply a manual controller, but only that personal intervention is necessary.

Outlet - A point on the wiring system at which current is taken to supply utilization equipment.

Overcurrent - Any current in excess of the rated current of equipment or the ampacity of a conductor. It may result from overload, short circuit, or ground fault.

Overload - Operation of equipment in excess of normal, full-load rating, or of a conductor in excess of rated ampacity that, when it persists for a sufficient length of time, would cause damage or dangerous overheating. A fault, such as a short circuit or ground fault, is not an overload.

Panelboard - A single panel or group of panel units designed for assembly in the form of a single panel, including buses and automatic overcurrent devices, and equipped with or without switches for the control of light, heat, or power circuits; designed to be placed in a cabinet or cutout box placed in or against a wall, partition, or other support; and accessible only from the front.

Plenum - A compartment or chamber to which one or more air ducts are connected and that forms part of the air distribution system.

Power Outlet - An enclosed assembly that may include receptacles, circuit breakers, fuse holders, fused switches, buses, and watt-hour meter mounting means; intended to supply and control power to mobile homes, recreational vehicles, park trailers, or boats or to serve as a means for distributing power required to operate mobile or temporarily installed equipment.

Raceway - An enclosed channel of metal or nonmetallic materials designed expressly for holding wires, cables, or busbars, with additional functions as permitted in this Code. Raceways include, but are not limited to, RMC, RNMC, IMC, LFC, FMT, FMC, ENMT, EMT, underfloor raceways, cellular concrete floor raceways, cellular metal floor raceways, surface raceways, wireways, and busways.

Rainproof - Constructed, protected, or treated so as to prevent rain from interfering with the successful operation of the apparatus under specified test conditions.

Raintight - Constructed or protected so that exposure to a beating rain will not result in the entrance of water under specified test conditions.

Receptacle - A receptacle is a contact device installed at the outlet for the connection of an attachment plug. A single receptacle is a single contact device with no other contact device on the same yoke. A multiple receptacle is two or more contact devices on the same yoke.

Receptacle Outlet - An outlet where one or more receptacles are installed.

Service - The conductors and equipment for delivering electric energy from the serving utility to the wiring system of the premises served.

Service Cable - Service conductors made up in the form of a cable.

Service Conductors - The conductors from the service point to the service disconnecting means.

Service Drop - The overhead service conductors from the last pole or other aerial support to and including the splices, if any, connecting to the service-entrance conductors at the building or other structure.

Service-Entrance Conductors, Overhead System - The service conductors between the terminals of the service equipment and a point usually outside the building, clear of building walls, where joined by tap or splice to the service drop.

Service-Entrance Conductors, Underground System - The service conductors between the terminals of the service equipment and the point of connection to the service lateral.

Service Equipment - The necessary equipment, usually consisting of a circuit breaker(s) or switch(es) and fuse(s) and their accessories, connected to the load end of service conductors to a building or other structure, or an otherwise designated area, and intended to constitute the main control and cutoff of the supply.

Service Lateral - The underground service conductors between the street main, including any risers at a pole or other structure or from transformers, and the first point of connection to the service-entrance conductors in a terminal box or meter or other enclosure, inside or outside the building wall. Where there is no terminal box, meter, or other enclosure, the point of connection is considered to be the point of entrance of the service conductors into the building.

Service Point - The point of connection between the facilities of the serving utility and the premises wiring.

Show Window - Any window used or designed to be used for the display of goods or advertising material, whether it is fully or partly enclosed or entirely open at the rear and whether or not it has a platform raised higher than the street floor level.

Signaling Circuit - Any electric circuit that energizes signaling equipment.

Switch, Transfer - An automatic or non-automatic device for transferring one or more load conductor connections from one power source to another.

Switchboard - A large single panel, frame, or assembly of panels on which are mounted on the face, back, or both, switches, overcurrent and other protective devices, buses, and usually instruments. Switchboards are generally accessible from the rear as well as from the front and are not intended to be installed in cabinets

Thermal Protector (as applied to motors) - A protective device for assembly as an integral part of a motor or motor-compressor that, when properly applied, protects the motor against dangerous overheating due to overload and failure to start.

Utilization Equipment - Equipment that utilizes electric energy for electronic, electromechanical, chemical, heating, lighting, or similar purposes.

Volatile Flammable Liquid - A flammable liquid having a flash point below 38°C, or a flammable liquid whose temperature is above its flash point, or a Class II combustible liquid that has a vapor pressure not exceeding 276 kPa at 38°C and whose temperature is above its flash point.

Voltage (of a circuit) - The greatest root-mean-square (RMS/effective) difference of potential between any two conductors of the circuit concerned.

Voltage, Nominal - A nominal value assigned to a circuit or system for the purpose of conveniently designating its voltage class (e.g., 120/240 volts, 480Y/277 volts, 600 volts). The actual voltage at which a circuit operates can vary from the nominal within a range that permits satisfactory operation of equipment.

Voltage to Ground - For grounded circuits, the voltage between the given conductor and that point or conductor of the circuit that is grounded; for ungrounded circuits, the greatest voltage between the given conductor and any other conductor of the circuit.

Watertight - Constructed so that moisture will not enter the enclosure under specified test conditions.

Weatherproof - Constructed or protected so that exposure to the weather will not interfere with successful operation

PERMITS AND INSPECTION CERTIFICATES

Places to Obtain Permits:

- Local Building Office - buildings, trailers, mobiles homes
- *Marina*(Maritime Industry Authority) - watercrafts

Requirements for Electrical Permit:

a) **Information**

1. Applicant
2. PEE who signed and sealed the electrical plans and specifications
3. Licensed Electrical Practitioner who is in charge of electrical works
4. Building Owner
5. Lot Owner
6. Building Official

b) **5 SETS of complete electrical plans and specifications signed and sealed by PEE**

The delay for releasing an electrical permit shall not be longer than five (5) working days after which time application together with the accompanying plans

Reconnection of Disconnected Service

- If service has been cut off for more than 1 year, electrical inspection cert. is required.

ELECTRICAL PLANS AND SPECIFICATIONS

Drawing Sheet Sizes

- Electrical plans and drawings shall be drawn on drawing sheets of the following standard sizes:

- ✓ 760 mm x 1,000 mm
- ✓ 600 mm x 900 mm
- ✓ 500 mm x 760 mm

* For dwelling units 297 mm x 420mm (A3 Size is allowed)

Plan Requirements:

- a) **Location and Site Plans** - Proposed structure and owner's land drawn with the ff. information:
 1. Bordering areas showing public or well-known streets, landmarks and/or structures.
 2. Location of service drop, service equipment and nearest pole of the utility company furnishing electrical energy.
 3. Location of the meter; Sizes of service entrance wires, conduits and service equipment.
 4. Clearance of the path or run of service drop and entrance wires to adjacent and/ or proposed structures.
- b) **Legend or Symbols**
- c) **General Notes and/or Specifications**
 1. Nature of electrical service, number of phases, number of wires, voltage and frequency.
 2. Type of wiring
 - Service entrance
 - Feeders, sub-feeders and branch circuit wires for lighting and/or power load.
 - Fire alarm system (if required)
 - Signaling and communication
 3. Special equipment to be installed, with ratings, classification of service or duty cycle.
 4. System or method of grounding.
 5. Type and rating of main disconnecting means, overcurrent protection (OCP) and branch circuit wiring.
 6. Clearances of service drop, burial depth for service lateral, mounting height and clearance for service equipment, mounting height and clearance for kWh meter.
- d) **Electrical Layout**
 1. **Plan for Power**
 - Sizes and location of service entrance conductors, raceways, metering equipment, main switchboard, layout of feeders and distribution panels or switches and their sizes, types and ratings.
 - Complete circuits of motors and other electrical equipment, their controlling devices, their locations and ratings.
 - Complete wiring of emergency power system (if any).
 - Nature of processes/activities carried out in each room or area.
 2. **Plan for Lighting and Receptacle Outlets**
 - Location, type and rating of lighting fixtures, indicating illumination in lux in each room or area. In residences, hotels, apartment houses, and churches, the illumination level in each room or area need not be shown nor computed.
 - Location of switches for each fixtures or group of fixtures.
 - Location of receptacle outlets and appliances to be served and their ratings.
 - Complete circuits of the lighting and receptacle outlets.
 - Complete wiring of emergency lighting system (if any).
 - A separate drawing showing layout of receptacle outlets may be made at the discretion of the design engineer.

3. **Plan for Fire Alarm Circuits** - Layout and wiring plans of fire alarm station, fire alarm bell, and fire alarm control panel.
- e) **Schedule of Loads**
 1. Motor Loads
 2. Lighting and Receptacle Loads
 3. Other Loads
- f) **Design Analysis**
 1. Branch circuits, sub-feeders, feeders, busways, and service entrance
 2. Types, ratings, and trip setting of overload protective devices
 3. Short circuit current for interrupting capacity
 4. Voltage drop calculations
- g) **One Line Diagram**
 1. Lighting and Receptacle Outlet Loads
 2. Motor Loads
 3. Feeders and Subfeeders
 4. Load Centers

Title Block or Nameplate of Plans and Drawing

- Shall be made of standard strip 40mm high at the bottom of the sheet.

1. Name and location of installation of project.
2. Name, signature and address of owner/ manager/ operator
3. Title of sheet
4. PEE name and signature with PRC license number, Tax Identification number.
5. Scale used, date drawn
6. Sheet number

Other Details for Electrical Plans

1. Exposed conductors
 - Means of support and types of insulators
 - Spacings and clearances
2. Auxiliary gutters, wireways, busways, cabinets, boxes, metallic raceways, underground installations.
 - Installation details
 - Conductor supports, separators, and attachments
3. Private pole installations
 - Construction and installation details and dimensions
 - Pole top wiring details including line hardware
 - Guying detail
4. Low energy power and low voltage power installation
 - Details of battery installation and source of power
 - Equipment, wiring, actuating mechanism and protective devices

Substation Plans and Specifications

Indoor Substation

1. Location and dimensions of:
 - a) Substation in building plan drawn to scale
 - b) Building with respect to entire compound or property
 - c) Incoming and outgoing lines
 - d) Windows, doors, and other openings

2. Substation structural requirements:
 - a) Materials & construction of walls, floors, roof, windows, enclosures, doors (with dimensions)
 - b) Ventilation and drainage systems and other safeguards
3. Substation electrical requirements
 - a) Plan view showing location and size of equipment installed
 - b) Clearances and spacings between exposed current-carrying and non-current carrying portions
 - c) Grounding system
4. Cross sectional views
 - a) Horizontal and vertical clearances between exposed parts
 - b) Horizontal and vertical clearances of exposed parts from floor/ceiling
 - c) Finished floor level and ground level
5. Miscellaneous
 - a) Specification of equipment
 - b) Wiring of lighting and remote control systems
 - c) One-line diagrams of entire installation with voltage indicated
 - d) Computations on size of wires, busbar, transformer, fuses, switches and breaker
 - e) Class of insulation or insulators

Outdoor Substation

- Outdoor substation plans shall show same items as indoor substation except that in lieu of walls and roof, details of fence and supporting steel structure.

REQUIREMENTS FOR ELECTRICAL INSTALLATIONS

The Criteria for Examination of Electrical Inspection:

1. Suitability for the installation
2. Mechanical strength and durability
3. Wire bending and connection space
4. Electrical insulation
5. Heating effects produced by the equipment under normal and abnormal condition of use.
6. Arcing effects
7. Class, type, size, voltage, ampacity, specific use of equipment.

Entrance to Working Space

- a) **Large equipment** - equipments rated 1200 amperes or more shall have at least one entrance.
 - 600 mm wide
 - 2000 mm high
- b) **Headroom** - The minimum headroom of working spaces about service equipment, switchboards, panelboards, or motor control centers shall be 2000 mm.

Table 1.10.2.1(a)(1) Working Spaces			
Nominal Voltage to Ground	Minimum Clear Distance (mm)		
	Condition 1	Condition 2	Condition 3
0-150	900	900	900
151-600	900	1 000	1 200

Table 1.10.3.2 Minimum Distance from Fence to Live Parts	
Nominal Voltage	Minimum Distance to Live Parts (m)
601 - 13,799	3.05
13,800 - 230,000	4.57
Over 230,000	5.49

Note: For clearances of conductors for specific system voltages and typical BIL ratings, see ANSI C2-2002, National Electrical Safety Code.

Table 1.10.3.5(a) Minimum Depth of Clear Working Space at Electrical Equipment			
Nominal Voltage to Ground	Minimum Clear Distance (mm)		
	Condition 1	Condition 2	Condition 3
601-2500 V	900	1 200	1 500
2501-9000 V	1 200	1 500	1 800
9001-25,000 V	1 500	1 800	2 700
25,001V-75 kV	1 800	2 400	3 000
Above 75 kV	2 400	3 000	3 600

Table 1.10.3.5(e) Elevation of Unguarded Live Parts Above Working Space	
Nominal Voltage Between Phases	Elevation (mm)
601-7500 V	2 700
7501-35,000 V	2 900
Over 35 kV	2 900 + 9.5 /kV above 35kV

Warning Sign for Voltages Exceeding 600 Volts

“DANGER - HIGH VOLTAGE - KEEP OUT”

Measurements for Access to Manholes

- a) Rectangular access openings (650 mm x 550mm)
- b) Round access openings (650 mm diameter)

CHAPTER 2 - WIRING AND PROTECTION

USE AND IDENTIFICATION OF GROUNDED CONDUCTORS

Means of Identifying Grounded Conductors

- a) **Sizes 14 mm² or Smaller**
 - Continuous white or gray outer finish.
 - Three continuous white stripes on other than green insulation along its entire length.
- b) **Sizes Larger Than 14 mm²**
 - Continuous white or gray outer finish.
 - Three continuous white stripes along its entire length other than green insulation.
 - At the time of installation, distinctive white or gray marking at its termination.
- c) **Flexible Cords**
 - Shall be identified by a white or gray outer finish.
- d) **Grounded Conductors of Different Systems**
 - Shall have the grounded conductors for different systems distinguishable, one having white outer finish and the other a gray outer finish, other than green.

BRANCH CIRCUITS

Rating

- a) **In General** - The rating for other than individual branch circuits shall be 15, 20, 30, 40, and 50A.
- b) **Over 50 Amperes** - Multi-outlet branch circuits greater than 50A shall be permitted to supply non-lighting outlet loads.

Ground Fault Circuit Interrupter Protection

- a) **Dwelling Units** - All 125/250 volts, single phase, 15-20 amperes receptacles installed in the following locations shall be of GFCI protection:
 1. Bathrooms
 2. Garages, and also accessory buildings that have a floor located below grade level
 3. Outdoors
 4. Crawl spaces - at or below grade level
 5. Unfinished basements (not habitable rooms such as storage areas, work areas)
 6. Kitchen (receptacles on countertops)
 7. Laundry circuits, and wet bar sinks (receptacles within 1800 mm from the edge of sink)
 8. Boathouses
- b) **Other Than Dwelling Units** - All 125/250 volts, single phase, 15-20 amperes receptacles installed in the following locations shall be of GFCI protection:
 1. Bathrooms
 2. Commercial and institutional kitchens
 3. Rooftops
 4. Outdoor in public areas
- c) **Boat Hoists** - All 125/250 volts, 15-20 ampere receptacles shall be GFCI protection.

Circuits Derived from an Autotransformer

- Branch circuits shall not be derived from autotransformers unless the circuit being supplied has a grounded conductor connected to the supplying autotransformer supply.

Arc-Fault Circuit Interrupter (AFCI)

- A device intended to provide protection from the effects of arc faults by recognizing characteristics unique to arcing and by functioning to de-energize the circuit when an arc fault is detected.

Dwelling Unit Bedrooms

- All 115V and/or 230V, single phase, 15 and 20A shall be protected by a listed AFCI, combination type installed to provide protection of the branch circuit. This requirement is effective since last January 1, 2014.

BRANCH-CIRCUIT RATINGS

Conductors - Minimum Ampacity and Size

1. **In General** - Branch-circuit conductors shall have an ampacity not less than the maximum load to be served. Branch circuit conductors which supplies continuous load and combination thereof shall have an ampacity not less than 125% of the continuous load.
2. **Household Ranges and Cooking Appliances** - Fore ranges of 8¾ kW or more rating, shall have a minimum-branch circuit rating of 40 amperes.

Branch circuit conductors that supply other loads, other than cooking and heating appliances shall have a conductor not smaller than 2.0 mm² (1.6 mm dia.)

Branch Circuits requiring at least 20A Overcurrent Protection -1500VA

1. Small Appliance Branch Circuits
2. Laundry Branch Circuits
3. Bathroom Branch Circuits
4. Dwelling Unit (50 m²) not more than 3680VA

Permissible Loads

- A branch circuit supplying two or more outlets or receptacles shall supply only the loads specified.

1. **15-20 Ampere Branch Circuits**
 - Lighting Units, Utilization Equipments fastened in place, or combination of both
2. **30 Ampere Branch Circuits**
 - Fixed Lighting Units with Heavy-Lampholders other than Utilization Equipments
3. **40-50 Ampere Branch Circuits**
 - Cooking Appliances that are fastened to place
4. **Branch Circuits Larger than 50 Amperes**
 - Shall only supply non-lighting outlet loads

Receptacle Outlets

- a) **General Provisions** - In every kitchen, family room, dining room, living room, parlor, library, den, sunroom, bedroom, recreation room, or similar room or area of dwelling units, receptacle outlets shall be installed in accordance with the following provisions:
 1. **Spacing** - Not more than 1800 mm (1.8m) horizontally from the other receptacle outlet.
 2. **Wall Space** - Shall provide outlets for any space 600 mm or more than in width (including space measured around corners) and unbroken along the floor line by doorways, fireplaces, etc.
 3. **Floor Receptacles** - Not counted as part of the required num. of receptacle unless 450mm away from the wall.
- b) **Countertops** - In kitchens and dining rooms of dwelling units, receptacle outlets shall be of the installed in accordance with the following:
 1. **Wall Counter Spaces** - Counter spaces that are 300 mm or wider requires a receptacle be installed 600 mm measured horizontally from it.
 2. **Island or Peninsular Counter Spaces** - At least one receptacle shall be installed at each island counter space with a long dimension of 600 mm or greater and a short dimension of 300 mm or greater. When a rangetop or sink is dividing the island at dimensions of less than 300 mm, outlets are not required.
 3. **Receptacle Outlet Location** - Receptacle outlets shall be located above, but not more than 500 mm above, the countertop.

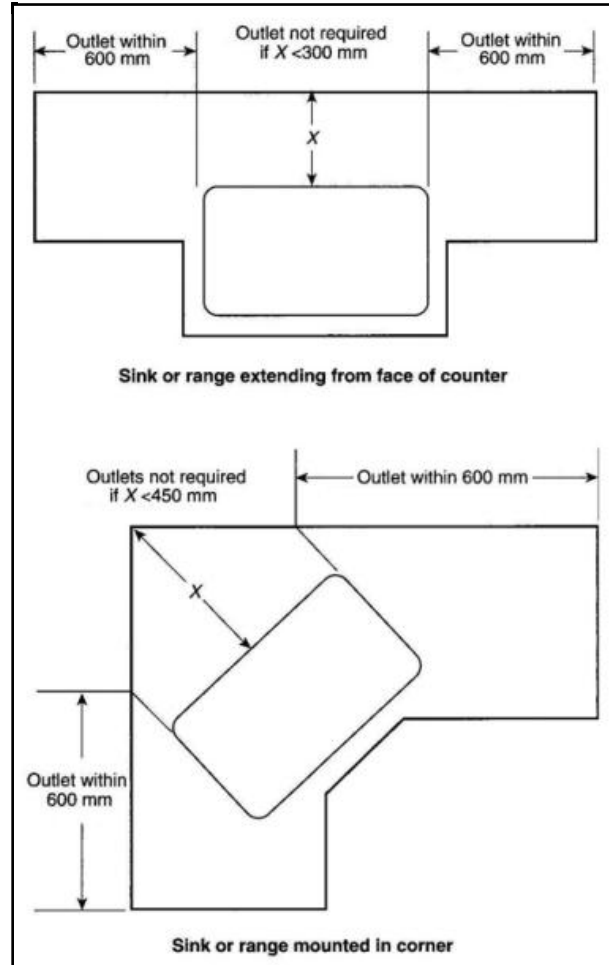

- c) **Bathrooms** - Shall have at least one receptacle within 900 mm from the outside edge of each basin.
- d) **Outdoor Outlets** - For a one-family dwelling and each unit of dwelling units shall have at least one accessible outlet at grade level not more than 2000 mm in front and back of the dwelling unit.
- e) **Laundry Areas** - Shall have at least one receptacle installed for the laundry.
- f) **Basement and Garages** - Shall have at least one receptacle outlet be installed.
- g) **Hallways** - In dwelling units, 3000 mm (3m) or more in length shall require at least one receptacle outlet.
- h) **Show Windows** - At least one receptacle directly above for each 3600 mm linear width.
- i) **Heating, Air-conditioning and Refrigeration Equipment Outlet** - Special individual outlets shall be installed and be located on the same level 7600 mm within the equipment.

Lighting Outlets Required

1. Habitable Rooms
2. Hallways, Stairways, Attached Garages, Detached Garages with Electric Power
3. Attached and Detached Garages
4. Interior Stairways (six risers or more)
5. Storage and Equipment Spaces
6. Guest Rooms or Guest Suites

FEEDERS

Minimum Rating and Size

- a) **In General** - Feeders shall have an allowable ampacity not less than the noncontinuous load plus 125% of the continuous load.
- b) **Ampacity Relative to Conductors** - Feeders for systems with 600 volts, or less, shall have an ampacity not less than that of the service and carry the total load supplied with 55 amperes or less.

Feeders with Common Neutral

- Two or three sets of 3-wire feeders or two sets of 4-wire or 5-wire feeders can have common neutral.

BRANCH CIRCUIT, FEEDER, AND SERVICE CALCULATIONS

Calculations

- a) **Voltages** - Unless other voltages are specified, for purposes of calculating branch-circuit and feeder loads, nominal system voltages of 115, 115/230, 208Y/120, 230, 347, 400Y/230, 460Y/265, 460, 600Y/347, and 600V shall be used.
- b) **Fractions of an Ampere** - An ampere that is less than 0.5, shall be permitted to be dropped.
- c) **Other Loads - All Occupancies**
 - 1. **Heavy-Duty Lampholders** - Outlets shall be calculated at minimum of 600VA.
 - 2. **Sign and Outline Lighting** - Outlets shall be calculated at minimum of 1200VA.
 - 3. **Show Windows** - Shall be calculated at 200VA per 300 mm show window.
 - 4. **Track Lighting** - 150VA included for every 600 mm of track lighting.
 - 5. **Banks and Office Buildings** - The receptacle loads shall be calculated at 28VA/m²
 - 6. **Receptacle Outlets**
 - 1 Yoke - Each single or multiple receptacle is 180VA
 - Multiple Receptacles (4 or more) - 90 VA per receptacle

General Lighting Loads by Occupancy	
Type of Occupancy	Unit Load (VA/m²)
Storage Spaces	2
Warehouses (Storage)	2
Halls, Corridors, Closets, Stairways	4
Garages (Commercial Storage)	4
Armories and Auditoriums	8
Assembly Halls and Auditoriums	8
Churches	8
Lodge Rooms	12
Clubs and Restaurants	16
Court Rooms	16
Hospitals	16
Hotels and Motels, including apartment houses without provision for cooking by tenants	16
Barber shops and Beauty parlors	24
Dwelling Units	24
Schools	24
Stores	24
Banks	28
Office Buildings	28

Feeder and Service Load Calculation

- a) **General Lighting**- The demand factors shall apply to that portion of the total branch-circuit load calculated for general illumination. Shall not be used for determining the number of luminaires.

Lighting Load Demand Factors		
Type of Occupancy	Portion of Lighting Load	Demand Factor
Dwelling Units	✓ First 3000 VA	100
	✓ 3001 VA - 120,000 VA	35
	✓ Remainder over 120,000 VA	25
Hospitals	✓ First 50,000 VA or less	40
	✓ Remainder over 50,000 VA	20
Hotels and Motels, including apartment houses without provision for cooking by tenants	✓ First 20,000 VA or less	50
	✓ 20,001 VA - 100,000 VA	40
	✓ Remainder over 100,000 VA	30
Warehouses (storage)	✓ First 12,500 VA or less	100
	✓ Remainder over 12,500 VA	50
All Others	✓ Total Volt-Ampere	100

- b) **Show Windows** - A load of not less than 660VA/linear meter shall be included for a show window, measured horizontally along its base.
- c) **Track Lighting** - Shall include an additional load of 150VA included for every 600 mm of track lighting
- d) **Electric Clothes Dryers - Dwelling Unit(s)** - The load shall be either 5000 watts (VA) or the nameplate rating, whichever is larger, for each dryer served.

Demand Factors for Household Electric Clothes Dryer	
Number of Dryers	Demand Factor
1-4	100%
5	85%
6	75%
7	65%
8	60%
9	55%
10	50%
11	47%
12-22	% = 47% - (number of dryers - 11)
23	35%
24-42	% = 35 - [0.5 x (number of dryers - 23)]
43 and over	25%

- e) **Kitchen Equipment** - It shall be permissible to calculate the load for commercial electric cooking equipment, dishwasher booster heaters, water heaters, and other kitchen equipment in accordance to the table.

Number of Units of Equipment	Demand Factor (Percent)
1	100
2	100
3	90
4	80
5	70
6 and over	65

- f) **Electric Ranges and Other Cooking Appliances** - The load for household electric ranges, wall-mounted ovens, counter-mounted cooking units, and other household cooking appliances individually rated in excess of 1¾ kW shall be permitted to be calculated in accordance to this table:

Table 2.20.3.16 Demand Factors and Loads for Household Electric Ranges, Wall-Mounted Ovens, Counter-Mounted Cooking Units, and Other Household Cooking Appliances over 1¾ kW Rating (Column C to be used in all cases except as otherwise permitted in Note 3.)

Number of Appliances	Demand Factor (Percent) (See Notes)		Column C Maximum Demand (kW) (See Notes) (Not over 12 kW Rating)
	Column A (Less than 3¾ kW Rating)	Column B (3¾ kW to 8¾ kW Rating)	
1	80	80	8
2	75	65	11
3	70	55	14
4	66	50	17
5	62	45	20
6	59	43	21
7	56	40	22
8	53	36	23
9	51	35	24
10	49	34	25
11	47	32	26
12	45]	32	27
13	43	32	28
14	41	32	29
15	40	32	30
16	39	28	31
17	38	28	32
18	37	28	33
19	36	28	34
20	35	28	35
21	34	26	36
22	33	26	37
23	32	26	38
24	31	26	39
25	30	26	40
26-30	30	24	15 kW + 1 kW for each range
31-40	30	22	25 kW + ¾ kW for each range
41-50	30	20	
51-60	30	18	
61 and over	30	16	

1. Over 12 kW through 27 kW ranges all of same rating. For ranges individually rated more than 12 kW but not more than 27 kW, the maximum demand in Column C shall be increased 5 percent for each additional kilowatt of rating or major fraction thereof by which the rating of individual ranges exceeds 12 kW.

Optional Feeder and Service Load Calculations

✓ **Heating and Air-Conditioning Load**

- a) 100% - Air-Conditioning and Cooling
- b) 100% - Heat Pump without any Supplementary Electric Heating
- c) 100% - Electrical Thermal Storage
- d) 100% - Heat Pump Compressor and 65% - Supplemental Electric Heating
- e) 65% - Electric Space Heating less than 4 Controlled Units
- f) 40% - Electric Space Heating for 4 or more Controlled Units

Multifamily Dwelling

- It shall be permissible to calculate the load of a feeder or service that supplies three or more dwelling units of a multifamily dwelling in accordance with the table if all the following conditions are met:

- 1. No dwelling unit is supplied by more than one feeder.
- 2. Each dwelling unit is equipped with electric cooking equipment.

Number of Dwelling Units	Demand Factor (Percent)
3-5	45
6-7	44
8-10	43
11	42
12-13	41
14-15	40
16-17	39
18-20	38
21	37
22-23	36
24-25	35
26-27	34
28-30	33
31	32
32-33	31
34-36	30
37-38	29
39-42	28
43-45	27
46-50	26
51-55	25
56-61	24
62 and over	23

OUTSIDE BRANCH CIRCUITS AND FEEDERS

Conductor Size and Supports

- a) **Overhead Spans** - Individual conductors shall not be smaller than the following:
 - 1. **For 600 volts, nominal, or less**
 - 1. 15m Length - 5.5 mm² (2.6 mm. dia.) copper and 8.0 mm² (3.2 mm. dia.) aluminum
 - 2. Longer than 15m - 8.0 mm² (3.2 mm. dia.) copper and 14 mm² aluminum
 - 2. **For over 600 volts**
 - 1. Open Individual Conductors - 14 mm² copper and 22 mm² aluminum
 - 2. Conductors in Cable - 8.0 mm² (3.2 mm. dia.) copper and 14 mm² aluminum
- b) **Festoon Lighting** - Overhead conductors for festoon lighting shall not be smaller than 3.5 mm² (2.0 mm dia.) unless the conductors are supported by messenger wirings.

OPEN CONDUCTOR SPACING (CLEARANCES) - FEEDERS AND CONDUCTORS

Conductor on Poles

- Shall have a separation of not less than 300 mm where not placed on racks or brackets.
 - a) Power conductors below communications conductors - 750 mm
 - b) Power conductors alone or above communications conductors:
 - 1. 300V or less - 600 mm
 - 2. Over 300V- 750 mm
 - c) Communications conductors below power conductors - Same as power conductors
 - d) Communications conductors alone - No requirement

OVERHEAD SERVICE

Service Drop - The overhead service conductor from the last pole or other aerial support and including splices if any, connecting to the service entrance conductor in a building or other structures.

Overhead Service Locations

1. Equipped with rain-tight service head.
2. Located above the point of attachment of the service-drop conductors.
3. Drip loops formed on individual conductors to prevent moistures.
4. Arranged that water will not enter service raceway or equipment.

Overhead Service Drop Conductors - The minimum size of overhead service drop conductors:

- a) Copper - 8.0 mm² (3.2 mm dia.)
- b) Aluminum or Copper Clad - 14 mm²

Clearance from Ground

- Overhead spans of conductors not over 600V, nominal, shall have a clearance of not less than the following:
 - a) **3000 mm** - Above finished grade, sidewalks, pedestrians (150V per phase max.). And, at electric service entrance to buildings, also at the lowest point of the drip loop.
 - b) **3600 mm** - Over residential property, driveways, and commercial properties not subject to traffic where voltage does not exceeds 300V per phase max.
 - c) **4500 mm** - Over residential property, driveways, and commercial properties not subject to traffic where voltage exceeds over 300V per phase.
 - d) **5500 mm** - Over public streets, alleys, roads, parking areas subject to truck traffic, driveways, cultivated, grazing, forest, and orchard.
 - e) **6900 mm** - In any direction of the water level of swimming pools.

Clearances from Buildings for Conductors of Not Over 600 Volts, Nominal

- a) **Above Roofs** - Shall not be less than 2500 mm above roof surface and maintained at a distance not less than 900 mm in all directions from the edge of the roof.
 - **Voltage does not exceed 300V and the roof has a slope of 100 mm in 300 mm or greater** - A reduction of 900 mm in clearance is permitted.
- b) **From Non-Building or Non-Bridge Structures** - from signs, chimneys, radio and television antennas, tanks - vertical, diagonal, and horizontal - shall not be less than 900 mm.
- c) **Horizontal Clearances** - Clearances shall not be less than 900 mm
- d) **Finals Spans** - Final spans of feeders or branch circuits:
 1. **Clearance from Windows** - Shall be kept not less than 900 mm.
 2. **Vertical Clearance** - 900 mm measured horizontally of, platforms or projections.
 3. **Building Openings** - Overhead branch circuits shall not be installed beneath openings through which materials may be moved.
 4. **Zone for Fire Ladders** - A clear space (zone) at least 1800 mm wide left adjacent of the building to facilitate rising of ladders when necessary for fire fighting.

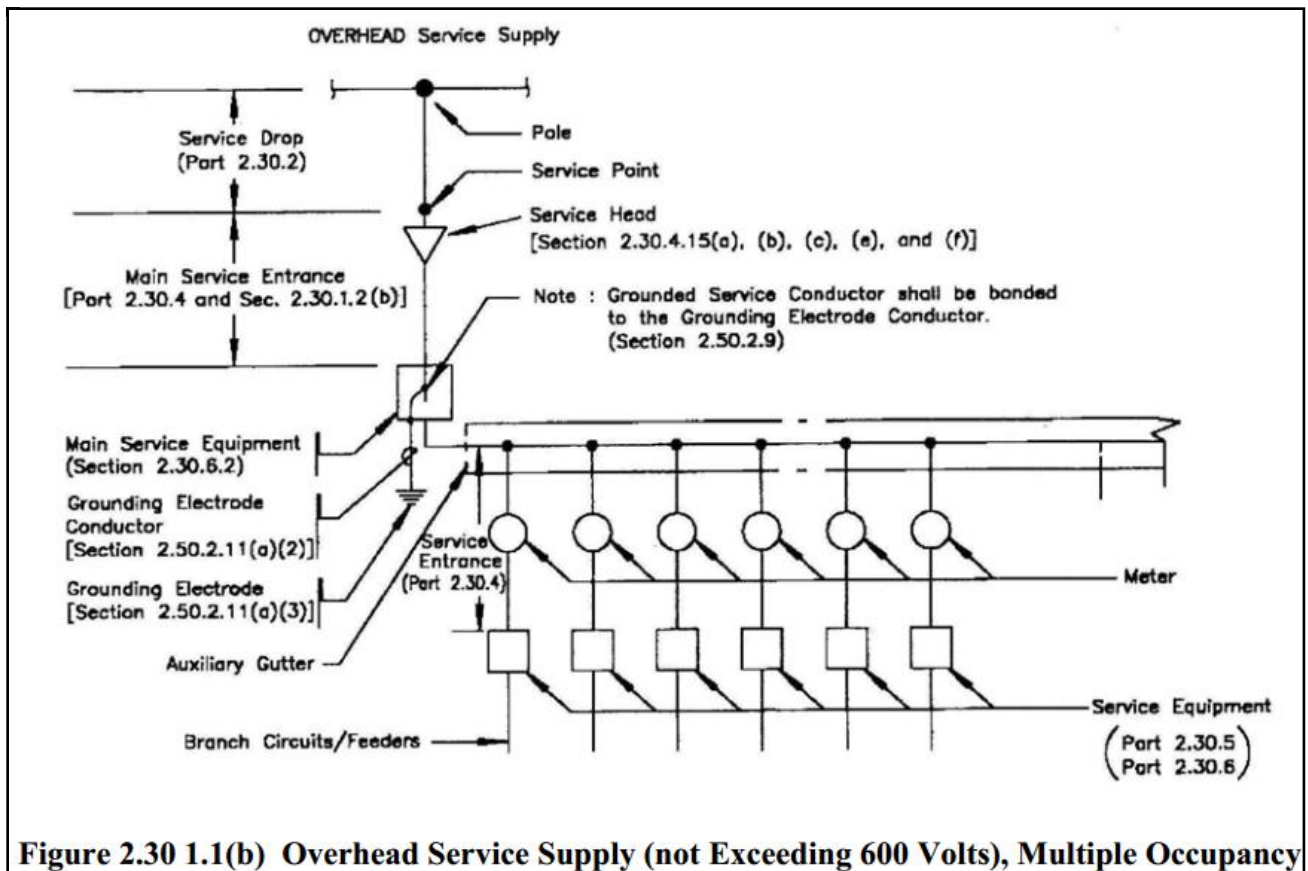
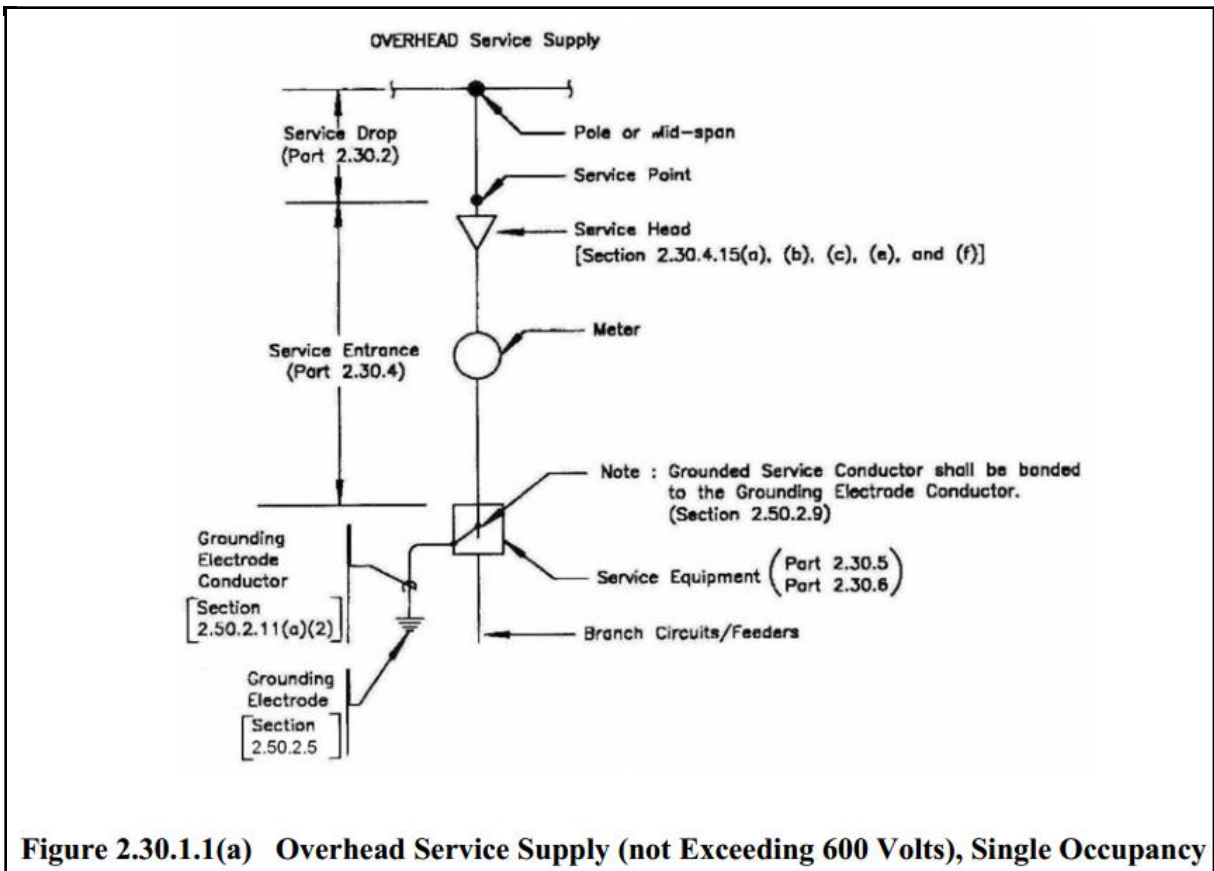

SERVICES

Service Entrance - The service conductors between the terminal of the service equipment and point usually outside the building, clear of building walls, where joined by a taps or splices to the service drop. A building or other structure served be supplied by *one service* only

Buildings or Structures requiring Additional Feeders/Service Entrance:

- a) **Special Conditions** - Additional feeder or branch circuits shall be permitted to the ff.
 1. Fire pumps (high pressure) for the building
 2. Emergency systems
 3. Legally required standby systems
 4. Optional standby systems
 5. Parallel power production systems
 6. Multiple sources of supply for the purpose of enhanced reliability
- b) **Special Occupancies** - By special permission, additional feeder or branch circuit shall be permitted:
 1. Multiple-occupancy buildings where there is no available space for service equipment accessible to all occupancies.
 2. A single building/structure sufficiently large to make two or more supplies necessary.
- c) **Capacity Requirements** - Where the capacity requirements are in excess of 2000 amperes at a supply voltage of 600V or less
- d) **Different Characteristics** - Additional services shall be permitted for different voltages, frequencies, or phases, or for different uses, such as for different rate schedules.
- e) **By Identification**

Conductors Considered Outside the Building

- The conductors considered outside the building shall be in the following conditions:

- a) Installed under not less than 50 mm of concrete beneath a building/structure
- b) Encased in concrete or brick not less than 50 mm thick
- c) Installed in any vault construction
- d) installed in conduit and under not less than 450 mm of earth burial

Location	Clearance (m)
Open land subject to vehicles, cultivation, or grazing	5.6
Roadways, driveways, parking lots, and alleys	5.6
Walkways	4.1
Rails	8.1
Spaces and ways for pedestrians and restricted traffic	4.4
Water areas not suitable for boating	5.2

Clearance from Conductors or Live Parts from:	Horizontal (m)	Vertical (m)
Building walls, projections, and windows	2.3	—
Balconies, catwalks, and similar areas accessible to people	2.3	4.1
Over or under roofs or projections not readily accessible to people	—	3.8
Over roofs accessible to vehicles but not trucks	—	4.1
Over roofs accessible to trucks	—	5.6
Other structures	2.3	—

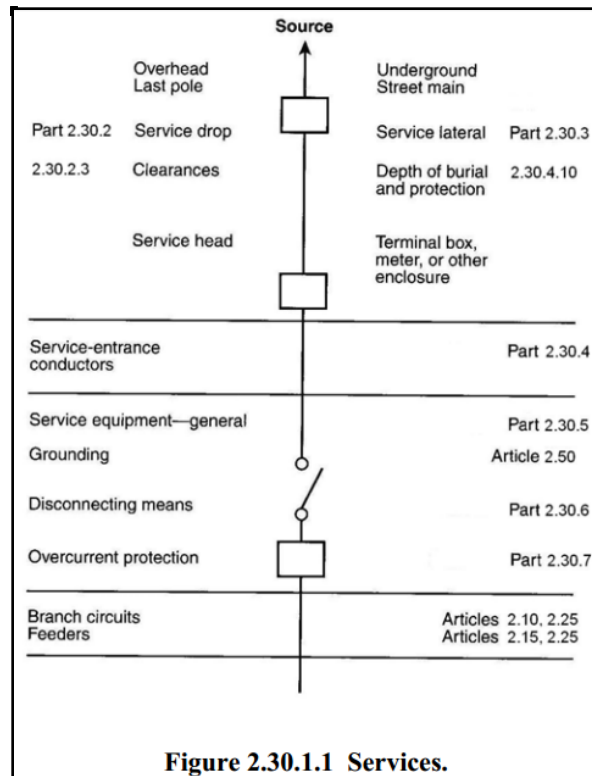

UNDERGROUND SERVICE

Service Lateral - the underground service conductors between the street main including any risers at a pole or other structure or from transformers, and the first point of connection to the service-entrance conductors in a terminal box or other enclosure, inside or outside the building wall. Where there is no terminal box, meter, or other enclosure, the point of connection is considered to be the point of entrance of the service conductors into the building.

Clearance of Service Lateral:

- a) **600 mm** - directly buried cable
- b) **150 mm** - RMC or IMC installation
- c) **450 mm** - PVC approved for direct burial without concrete encasement
- d) **450 mm** - other approved raceway for direct burial

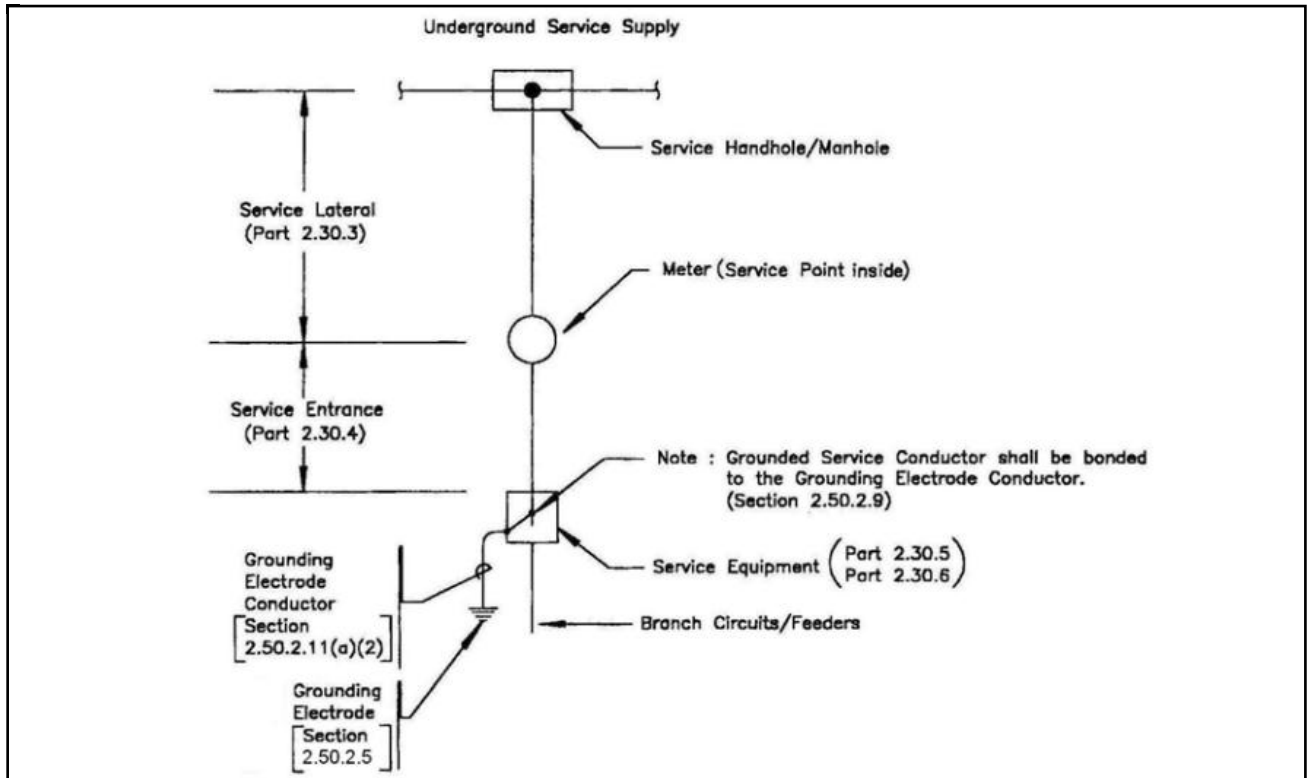

Figure 2.30.1.1 (c) Underground Service Supply (not Exceeding 600 Volts), Single Occupancy

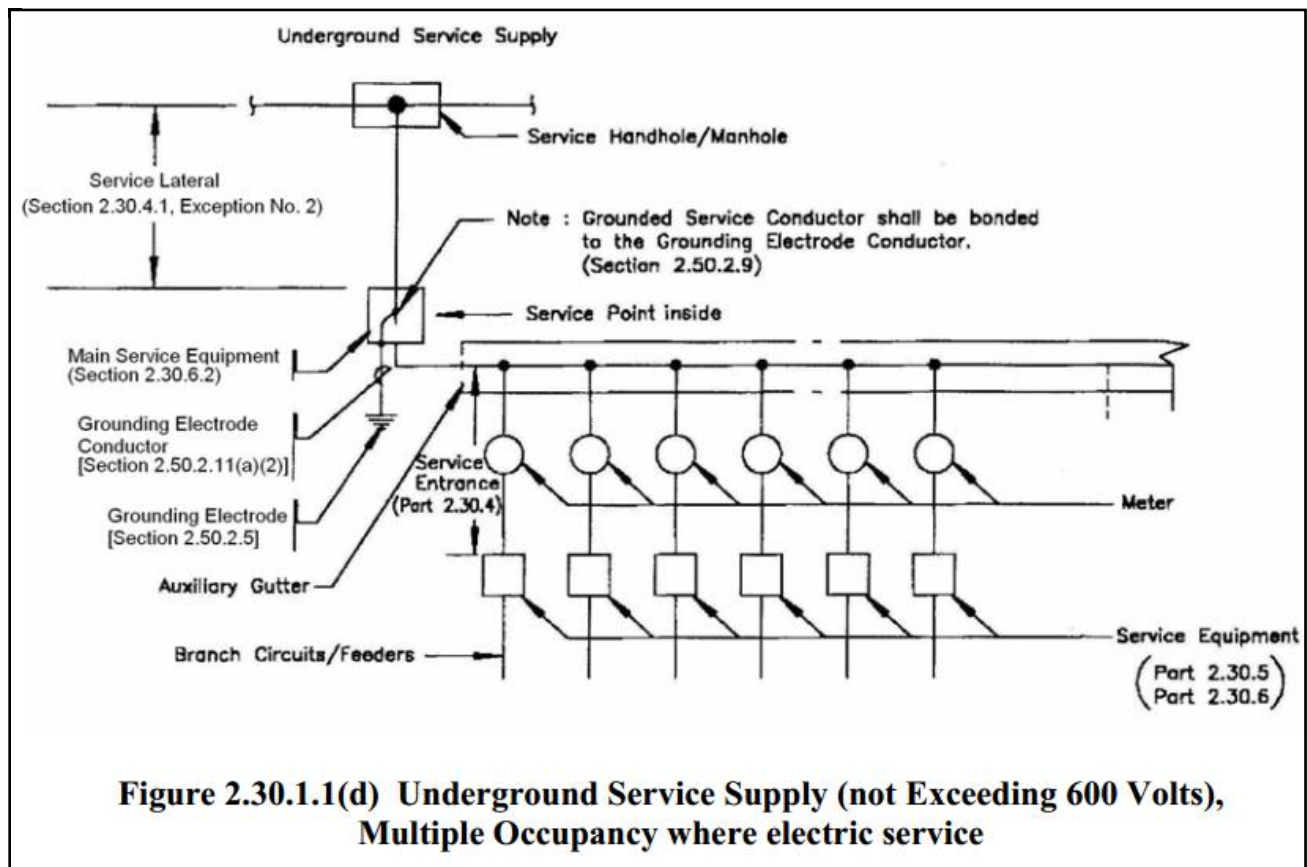

Figure 2.30.1.1(d) Underground Service Supply (not Exceeding 600 Volts), Multiple Occupancy where electric service

Mounting Supports

- Service cables shall be supported by straps or other approved means within 300 mm of every service head, gooseneck, or connection to a raceway or enclosure at intervals not exceeding 750 mm.

Equipments Connected to the Supply Side Service Disconnect:

- a) Cable limiters or other current-limiting devices
- b) Meters and meter sockets (not in excess of 600V)
- c) Meter disconnect switches (not in excess of 600V)
- d) Fusible switches or circuit breakers
- e) Instrument transformers (current and voltage), impedance shunts, load management devices, arresters
- f) Taps used only to supply load management devices
- g) Solar photovoltaic systems, fuel cell systems, interconnected electric power production sources
- h) Control circuits for power-operable service disconnecting means
- i) Ground-fault protection systems or transient voltage surge suppressors
- j) Fusible disconnect switch or circuit breaker

Services Exceeding 600 Volts, Nominal

- Conductors not smaller than 14 mm² unless in multi-conductor cable. Multi-conductor cable shall not be smaller than 8.0 mm² (3.2 mm dia.).

Maximum Number of Disconnects

- Shall consists of not more than 6 switches or sets of circuit breakers, or a combination thereof shall be in a group of separate enclosures in a switchboard.

Manually or Power Operable

- a) **Manually operable** - A manually operable switch or circuit breaker shall be equipped with a handle or other suitable operating means.
- b) **Powered-operated switch** - It can be manually or power-operable/circuit breaker, provided it can be opened by hand during power failure.

Rating of Service Disconnecting Means:

- The service disconnecting means shall have a rating not less than the load to be supplied and not lower than the specified in the following:

- a) **One Circuit Installation**- Supplying only limited loads of a single branch circuit; the service disconnecting means shall have a rating of not less than 15A.
- b) **One Circuit Installation-Dwelling Unit** - For dwelling units with a single branch circuit a service disconnect means of not less than 20A is permitted.
- c) **Two-Circuit Installations** - For installation of not more than 2 wire branch circuits, the service disconnecting means shall have a rating of not less than 30A.
- d) **One Family Dwelling** - The service disconnect shall have a rating of not less than 60A, 3-wire.
- e) **All Others** - Shall have a rating of not less than 30A.

OVERCURRENT PROTECTION

Current-Limiting Overcurrent Protective Device - A device that, when interrupting currents in its current-limiting range, reduces the current flowing in the faulted circuit to a magnitude substantially less than that obtainable in the same circuit if the device were replaced with a solid conductor having comparable impedance.

Tap Conductor - A conductor, other than a service conductor, that has overcurrent protection ahead of its point of supply that exceeds the value permitted for similar conductors that are protected.

Standard Ampere Ratings

- The standard ampere ratings for fuses and inverse time circuit breakers shall be considered 15, 20, 25, 30, 35, 40, 45, 50, 60, 70, 80, 90, 100, 110, 125, 150, 175, 200, 225, 250, 300, 350, 400, 450, 500, 600, 700, 800, 1000, 1200, 1600, 2000, 2500, 3000, 4000, 5000, and 6000 amperes. Additional standard ampere ratings for fuses shall be 1, 3, 6, 10, and 601. The use of fuses and inverse time circuit breakers with nonstandard ampere ratings shall be permitted.

Fuses or Circuit Breakers in Parallel

- Fuses and circuit breakers shall be permitted to be connected in parallel where they are factory assembled in parallel and listed as a unit. Individual fuses, circuit breakers, or combinations thereof shall not otherwise be connected in parallel.

Thermal Devices

- Thermal relays and other devices not designed to open short circuits or ground faults shall not be used for the protection of conductors against overcurrent due to short circuits or ground faults, but the use of such devices shall be permitted to protect motor branch-circuit conductors from overload if protected.

Grounded Conductor

- No overcurrent device shall be connected in series with any conductor that is intentionally grounded.

Change in Size of Grounded Conductor

- Where a change occurs in the size of the ungrounded conductor, a similar change shall be permitted to be made in the size of the grounded conductor.

Locations in or in Premises

- a) **Accessibility** - Overcurrent devices shall be readily accessible and shall be installed so that the center grip of the handle switch at its highest position is not more than 2 meters from the floor.
- b) **Occupancy** - each occupant shall have ready access to all overcurrent devices protecting the conductors supplying that occupancy.
- c) **Not Exposed in Physical Damage**
- d) **Not in Vicinity of Easily Ignitable Materials**
- e) **Not Located in Bathrooms**
- f) **Installed in a Vertical Position**

Circuit Breakers

- a) **Method of Operation** - Circuit breakers shall be trip free and capable of being closed and opened by manual operation. Their normal method of operation by other manual means, such as electrical or pneumatic, shall be permitted if means for manual operation are also provided.
- b) **Indication** - The indication of “up” position of the handle is “on” position and a “down” position is indicating it is in “off” position.
- c) **Nontamperable** - A circuit breaker shall be of such design that any alteration of its trip point (calibration) or the time required for its operation requires dismantling of the device or breaking of a seal for other than intended adjustments.

d) **Marking**

1. **Durable and Visible** - Circuit breakers shall be marked with their ampere rating in a manner that will be durable and visible after installation
2. **Location** - Circuit breaker rated at 100A or less and 600V or less shall have the ampere rating molded, stamped, etched or similarly marked into their handles.
3. **Interrupting Rating** - Each device with an interrupting rating other than 5000A shall have its interrupting rating shown on the circuit breaker.
4. **Used as Switches** - Circuit breakers used as switches in 120V and 277V fluorescent lighting circuits shall be listed and shall be marked SWD or HID.
5. **Voltage Marking** - Circuit breakers shall be marked with a voltage rating not less than the nominal system voltage that is indicative of their capability to interrupt fault currents between phases or phase to ground.

Overcurrent Protection over 600V, Nominal

- a) **Overcurrent Relays and Current Transformers** - Circuit breakers used for overcurrent protection of 3-phase circuits shall have a minimum of 3 overcurrent relay elements operated from 3-current transformers.
- b) **Fuses** - a fuse shall be connected in series with each ungrounded conductor.

GROUNDING AND BONDING

Effective Ground-Fault Current Path - An intentionally constructed, permanent, low-impedance electrically conductive path designed and intended to carry current underground-fault conditions from the point of a ground fault on a wiring system to the electrical supply source and that facilitates the operation of the overcurrent protective device or ground fault detectors on high-impedance grounded systems.

Ground Fault - An unintentional, electrically conducting connection between an ungrounded conductor of an electrical circuit and the normally non-current-carrying conductors, metallic enclosures, metallic raceways, metallic equipment, or earth.

Ground-Fault Current Path - An electrically conductive path from the point of a ground fault on a wiring system through normally non-current carrying conductors, equipment, or the earth to the electrical supply source.

Grounding Electrode Conductor - connects the equipment grounding conductors, the service-equipment enclosures to the grounding electrode(s)

General Requirements for Grounding and Bonding:

- a) **Electrical System Grounding** - Shall have connections that limit the voltage imposed by lightning, line surges, or unintentional contact with higher-voltage lines that will stabilize the voltage to earth.
- b) **Grounding of Electrical Equipment** - Non-current carrying conductive materials, electrical conductors, or equipment shall be connected to earth so as to limit the voltage to ground.
- c) **Bonding of Electrical Equipment** - Non-current carrying conductive materials forming part of such equipment connected together establishing an “*effective ground-fault current path*”.
- d) **Bonding of Electrically Conductive Material and Other Equipment** - Electrically conductive materials that are likely to be energized shall be connected together establishing “*effective ground-fault current path*”.
- e) **Effective Ground-Fault Current Path** - A low impedance current path for the fault current to carry the maximum ground-fault current.

Connection of Grounding and Bonding Equipment

- a) Connected by exothermic welding, listed pressure contactors, listed clamps.
- b) Connection devices or fittings that depend solely on solders shall not be used.
- c) Sheet metal screws shall not be used.
- d) Non-conductive coatings shall be removed such as paint, lacquer, and enamel.

Circuits Not To Be Grounded

1. Electric cranes operating over combustible fibers in Class III locations.
2. Circuits in health care facilities.
3. Circuits for equipment within electrolytic cell working zone.
4. Secondary circuits of lighting systems.

Main Bonding Jumper and System Bonding Jumper

1. Copper or other corrosion-resistant material.
2. Wire, bus, screw, or similar suitable conductor.
3. Screws shall be identified with a green finish.

Grounding Electrode Conductor for Multiple Separately Derived Systems

- The common grounding electrode conductor shall not be smaller than 80 mm² copper or 125 mm² aluminum.

Grounding Electrodes (Electrodes Permitted for Grounding)

- The following listed shall be permitted to be grounding electrodes and shall be bonded together to form the grounding system which limits the voltage to ground:

1. **Metal Underground Water Pipe** - Any metal underground water pipe 3000 mm or more and electrically continuous to the points of connection of the grounding electrode conductor and the bonding conductors.
2. **Metal Frame of the Building** - 3000 mm or more of a single structure metal member in direct contact with earth or encased in concrete that is in direct contact with the earth.
3. **Concrete Encased Electrode** - An electrode encased by at least 50 mm of concrete located near the bottom of concrete foundation or footing. It has 6000 mm of one or more electrically conductive steel coated bars.
4. **Ground Ring** - Bare copper conductor not smaller than 30 mm² encircling the building/structure. 6000 mm or more in length and buried at a depth not less than 750 mm
5. **Rod and Pipe Electrodes** - Rod and pipe electrodes shall not be less than 2400 mm in length.
 - a) Electrodes of pipe or conduit shall not be smaller than 20 mm.
 - b) Electrodes of iron or steel shall be at least 16 mm in diameter.
6. **Plate Electrodes** - Shall not expose (2ft²) 0.186 m² of surface to exterior. Iron or steel electrodes, 6 mm thick. Nonferrous metal electrodes, at least 1.5 mm thick. And, plate electrodes shall not be less than 750 mm below the earth's surface.
7. **Other Local Metal Underground Systems or Structures**

Electrodes Not Permitted for Grounding

1. Metal underground gas piping system
2. Aluminum electrodes

Bonding of Services

- The non-current carrying metal parts listed should be effectively bonded together:

- a) Service raceways, cable trays, cable framework, auxiliary gutters, service cable armor or sheath.
- b) Service enclosures containing service conductors, meter fittings, boxes, materials interposed in the service raceway or armor.
- c) Any metallic raceway or armor enclosing a grounding electrode.

Equipment Bonding Jumpers

- a) **Size - Equipment Bonding Jumper (Supply Side)** - The minimum size of bonding jumper shall be 8.0 mm² for copper and 14 mm² for aluminum or copper-clad aluminum.
- b) **Size - Equipment Bonding Jumper (Load Side)** - The largest underground circuit conductors supplying the equipment shall not be smaller than 2.0 mm² (1.6 mm. dia.).

Grounding Electrode Conductor for AC Systems			
Size of the Largest Underground Service-Entrance Conductor or Equivalent Area for Parallel Cond.		Size of Ground Electrode Conductor (mm²)	
Copper	Aluminum or Copper-Clad Aluminum	Copper	Aluminum or Copper-Clad Aluminum
30 or smaller	50 or smaller	8.0 (3.2)	14
38 or 50	60 or 80	14	22
60 or 80	100 or 125	22	30
Over 80 through 200	Over 125 through 250	30	50
Over 200 through 325	Over 250 through 400	50	80
Over 325 through 500	Over 400 through 850	60	100
Over 500	Over 850	80	125

Equipment Grounding and Equipment Grounding Conductors

- a) **Equipment Fastened in Place or Connected by Permanent Wiring Methods (Fixed)** - Exposed non-current carrying metal parts or fixed equipment that are likely to become energized shall be grounded:
 - 1. Where within 2400 mm vertically or 1500 mm horizontally of ground or grounded metal objects and subject to contact by persons.
 - 2. In a wet or damp location and not isolated.
 - 3. Where in electrical contact with metal.
 - 4. In hazardous locations.
 - 5. Supplied by a metal-clad, metal sheathed metal-raceway, or other equipment grounding methods.
 - 6. Operates with a terminal at over 150 volts to ground.
- b) **Equipment Fastened in Place or Connected by Permanent Wiring Methods (Fixed) - Specific** - Exposed, non-current carrying metal parts of the kinds of equipment and non-current carrying metal parts shall be grounded:
 - 1. Switchboard Frames and Structures
 - 2. Pipe Organs - generator and motor from frames in an electrically operated pipe organ.
 - 3. Motor Frames
 - 4. Enclosures for Motor Controllers
 - 5. Elevators and Cranes
 - 6. Garages, Theaters, and Motion Picture Studios
 - 7. Electric Signs
 - 8. Motion Picture Projection Equipment
 - 9. Power-Limited Remote-Control, Signaling, and Fire Alarm Circuits
 - 10. Luminaries (Lighting Fixtures)
 - 11. Skid Mounted Equipment
 - 12. Motor-Operated Water Pumps (including submersible type)
 - 13. Metal Well Casings
- c) **Equipment Connected by Cord and Plug**
 - 1. In hazardous locations
 - 2. Operated at over 150 volts to ground
 - 3. In residential and non residential occupancies:
 - Refrigerators, freezers, and air-conditioners
 - Clothes-washing, clothes-drying, dish-washing machines; kitchen waste disposer, IT equip. sump pumps and electrical aquarium equipments.
 - Hand-held motor-operated tools, stationary and fixed motor-operated tools, light industrial motor-operated tools.

- Motor-operated appliances of the following types: hedge clippers, lawn mowers, snow blowers, and wet scrubbers.
 - Portable handlamps
 - Cord-and-plug connected appliances used in damp or wet locations
 - Tools likely to be used in wet or conductive locations
- d) **Nonelectric Equipment** - Equipments listed shall be grounded:
- Frames and tracks of electrically operated cranes and hoists
 - Frames of non-electrically driven elevator cars to which electrical conductors are attached
 - Hand-operated metal shifting ropes or cable of electric elevators

Identification of Equipment Grounding Conductors

- a) Shall be permitted to be bare, covered, or insulated.
- b) Green or green with one or more yellow stripes outer finish.
- c) Minimum size of equipment grounding conductor is 2.0 mm² (1.6 mm. dia.) for copper and 3.5 mm² (2.0 mm. dia.) for copper aluminum or copper-clad aluminum

Rating or Setting of Automatic Overcurrent Device in Circuit Ahead of Equipment, Conduit, etc., Not Exceeding (Amperes)	Size mm ² (mm dia.)	
	Copper	Copper Aluminum or Copper-Clad Aluminum*
15	2.0(1.6)	3.5(2.0)
20	3.5(2.0)	5.5(2.6)
30	5.5(2.6)	8.0(3.2)
40	5.5(2.6)	8.0(3.2)
60	5.5(2.6)	8.0(3.2)
100	8.0(3.2)	14
200	14	22
300	22	30
400	30	38
500	30	50
600	38	60
800	50	80
1000	60	100
1200	80	125
1600	100	175
2000	125	200
2500	175	325
3000	200	325
4000	250	400
5000	400	600
6000	400	600

Identification of Wiring Device Terminals:

1. Green, not readily removable terminal screw with a hexagonal head.
2. Green, hexagonal, not readily removable terminal nut.
3. Green pressure wire connector. If the terminal is not visible, the conductor entrance hall shall be marked with the word green or ground, or letters “G” or “GR” or otherwise identified by distinctive green color.

Size of Direct-Current Grounding Electrode Conductor:

1. Shall not be smaller than 8.0 mm² for copper and 14 mm² aluminum.
2. Shall not be smaller than the largest conductor.
3. Connected to a rod, piper, or plate electrode.
4. Connected to a concrete-encased electrode.
5. Connected to a ground ring.

Instrument, Meters and Relays:

- a) **Such Cases should be Grounded:**
 - 1. Not on switchboards and at 300 volts or more.
 - 2. On dead-front switchboards having no live parts in front of the panel.
 - 3. On live-front switchboards having exposed live parts. Mats of insulating rubber should be provided for the operator where the voltage exceeds 150 volts.
- b) **Instrument Grounding Conductor**
 - The grounding conductor for secondary circuits of instrument transformers and for instrument cases shall not be smaller than 3.5 mm² (2.0 mm dia.) copper or 5.5 mm² (2.6 mm dia.) for aluminum.

SURGE ARRESTERS

Surge Arrester - A protective device for limiting surge voltages by discharging or bypassing surge current, and it also prevents continued flow of follow current while remaining capable of repeating these functions.

Surge Arrester Selection:

- a) **Circuits of less than 1000 Volts** - surge arresters installed on a circuit of less than 1000 volts shall comply with all of the following provisions:
 - 1. The rating shall be equal to or greater than the maximum continuous phase-to-ground power frequency voltage available at the point of application.
 - 2. Surge arresters installed on circuits of less than 1 000 volts shall be listed.
 - 3. With a short circuit current rating and shall not be installed at a point on the system where the available fault current is in excess of that rating.
 - 4. Shall not be installed on ungrounded systems, impedance grounded systems, or *corner grounded delta systems* unless listed specifically for use on these systems.
- b) **Circuits of 1kV and over -Silicon Carbide Types** - The rating of a silicon carbide-type surge arrester shall not be less than 125% of the maximum continuous phase-to-ground voltage.

TRANSIENT VOLTAGE SURGE SUPPRESSOR (TVSS)

Transient Voltage Surge Suppressor (TVSS) - A protective device for limiting transient voltages by diverting or limiting surge current; it also prevents continued flow of follow current while remaining capable of repeating these functions.

Uses Not Permitted

- A transient voltage surge suppressor shall not be installed in the following:
 - 1. Circuits exceeding 600 volts.
 - 2. On ungrounded systems, impedance grounded systems, or corner grounded delta systems unless listed specifically for use on these systems.
 - 3. Where the rating of the TVSS is less than the maximum continuous phase-to-ground power frequency voltage available at the point of application.

Conductor Size

- Line and ground connecting conductors shall not be smaller than 2.0 mm² (1.6 mm dia.) copper or 3.5 mm² (2.0 mm dia.) aluminum.

PROTECTION AGAINST LIGHTING

Definition:

Lighting Protection System - A complete system of air terminals, conductors, ground terminals, interconnecting conductors, arresters, and other connectors or fittings required to complete the system.

Rods and Points - Generic terms for the component parts.

Air Terminal - Capable to drawing lighting discharge to it in preference to vulnerable parts of the protected area. It may consist of a pointed, solid, or tubular rod or one with special design and material provided with a mounting base having a proper conductor connection.

Class I Materials - All conductors, fittings, and fixture for protection not exceeding 23 m in height.

Class II Materials - All conductors, fittings and fixtures for protection exceeding 23 m in height; or one which has a structural steel frame, of any height.

Copper-Clad Steel - Steel with a coating of copper to bond it

Counterpoise (ground) - A conductor encircling a building and inter-connecting all ground terminals

Fastener - An attachment to secure the conductor to the structure

Flame Protection - Self-closing gage hatches, vapor seals, pressure-vacuum breather valves, flame arresters, or other reasonably effective means to minimize the possibility of flame entering the vapor space of a tank.

Flammable Vapors - The vapors given from a flammable liquid at or above its flash point.

Flash Point - The minimum temperature at which it gives off vapor in sufficient concentration to form an ignitable mixture with air near the surface of the liquid within the vessel.

High-Rise Building - A building over 23m in height.

Metal Body of Conductance - Metal objects at the flat roof level subject to direct lighting stroke.

Metal Body of Inductance - Metal objects located 2000 mm of a conductor subject to buildup of potential.

Metal-Clad Building - Building with either sides or roof made of or covered with sheet metal.

Metal-Framed Building - Building with electrically continuous framing of sufficient size and conductivity.

Sideflash - A spark between nearby metallic objects to lighting protection system or to ground.

Spark Gap - Any short air space between two conductors electrically insulated to each other.

Stack, Heavy-Duty - A smoke/vent stack with greater than 0.32 m² and the height is greater than 23 m.

Vapor Openings - Openings for tank breathing, tank gaging, and fire fighting.

Zone of Protection - Provided by a grounded air terminal or mast or overhead ground wire which is immune to direct strokes of lighting.

Protection for Ordinary Buildings

- An ordinary building is one of common or conventional design and construction used for ordinary purposes, whether commercial, farm, industrial, institutional, or residential.

a) **Classifications**

1. Class I ordinary buildings - Less than 23 m in height.
2. Class II ordinary buildings - More than 23 m in height.

b) **Materials**

- The materials of which protection systems are made shall be resistant to corrosion or shall be acceptably protected against corrosion.

1. **Copper** - It shall be grade ordinarily designed with 98% conductivity when annealed.
2. **Copper Alloys** - It shall be substantially resistant to corrosion as copper.
3. **Aluminum** - When aluminum is used, care shall be taken not to use it in contact with the earth or elsewhere where it will rapidly deteriorate.

c) **Configuration**

- Gable, Hip, Broken Gable, Flat, Mansard, Gambrel

Terminals on Roofs

- a) **Flat or Gently Sloping Roofs** - Additional air terminals at intervals not exceeding 15m. Gently sloping are roofs having a span of 12m/less and a pitch of 1/8 or less or exceeding 12m with 1/4 pitch or less.
- b) **Lower Roofs** - One-to-one zone protection for buildings which exceed 15m above grade. One-to-two zone protection for buildings not exceeding 15m.
- c) **Dormers** - Higher than the main roof shall be protected with air terminals along end ridges.
- d) **Roofs with Intermediate Ridges** - Air terminals not exceeding 7600mm for roofs with parallel ridges.
- e) **Irregular Roof Lines** - Air terminals located within 600mm of the outermost projection of the roof edge.
- f) **Open Areas in Flat Roofs** - Shall be protected if their perimeter exceeds 92 m provided either rectangular dimension exceeds 15 m.
- g) **Doomed Or Curved Structures** - Air terminal located at the apex of the curve or dome.
- h) **Chimneys** - Air terminals shall be placed with 4.8 mm thick. Chimney air terminals shall be attached to the chimney so that no outside corner of the chimney is more than 600 mm from an air terminal.

Gradual Bends

- No bend of angle of less than 90 degrees nor shall have a radius of bend less than 230 mm

Two Way Path Exceptions

1. **One-Way Drops** - Permitted w/o an extra downlead provided lower roof conductor not more than 12m.
2. **Dead Ends** - Air terminals may be “dead ended” with only one path provided the conductor run from the air terminal to a main conductor is not more than 4900 mm in total length.

Down Conductors - At least two down conductors shall be provided of any kind of structure, including steeples.

1. **Number of Down Conductor** - Average distance between conductors shall not exceed 30m. Irregularly shaped structures may require extra down conductors to provide a two-way path to ground.
2. **Protecting Down Conductors** - Down conductors located in runways, driveways, school playgrounds, cattle yards, public walks shall be guarded to prevent from physical damage.

Grounding

1. **Ground Terminal (Rods)** - Shall be not less than 12.7 mm in dia. and 2400 mm long. Rods shall be copper-clad steel, solid copper or stainless steel.
2. **Ground Rod Clamps** - Clamps shall make contact with the ground rod for a distance of 38 mm. Clamps shall be secured with at least two bolts or cap screws.

Common Grounds

- All grounding mediums shall be bonded together which includes electric, telephone, antenna. Piping system including water service, well casings within 7600 mm, gas piping, underground conduits, underground liquefied petroleum-gas piping systems.

Metal Bodies

- a) **Bonding Requirements for Metal Bodies of Conductance** - Bonded to the system having a surface contact area of not less than 0.0019 m²
- b) **Bonding Requirements for Metal Bodies of Inductance** - Bonded to their closes point using secondary bonding conductors and fittings. Connections made within 1800 mm.

Anchors

- Masonry anchors shall have a diameter of not less than 6.4 mm and shall be set with care. Fit shall be tight against moisture and the effect of frost and capable of withstanding a pull test of 445N.

Splicers and Clamps

- Splicers and clamps shall be permitted to be connected to “end-to-end” “tee” or “Y” splices and shall withstand a pull test of 890N.

CHAPTER 3 - WIRING METHODS AND MATERIALS

APPROVED TYPE OF WIRING METHOD BY P.E.C.

a) **Conductors on Insulator Method:**

1. Open wiring on insulator - installed exposed*
2. Concealed knob and tube work - installed hidden by portion of the building*

b) **Cable Wiring Method:**

- | | |
|---|--|
| 1. Armored (BX) cable* | 7. Underground feeder & branch circuit cable |
| 2. Metal-clad cable | 8. Power and control tray cable |
| 3. Mineral insulated metal sheathed cable | 9. Flat conductor cable |
| 4. Non-metallic sheathed cable | 10. Medium voltage cable |
| 5. Shielded non-metallic sheathed cable | 11. Integrated gas spacer cable |
| 6. Service entrance cable | |

c) **Raceway Method**

- | | |
|--|-------------------------------------|
| 1. Intermediate metal conduit (IMC)* | 11. Underfloor raceway |
| 2. Rigid metal conduit (RMC)* | 12. Cellular metal floor raceway |
| 3. Rigid non-metallic conduit (PVC)* | 13. Cellular concrete floor raceway |
| 4. Electrical metallic tubing (EMT)* | 14. Wireways* |
| 5. Flexible metallic tubing (FMT)* | 15. Busways* |
| 6. Liquid-tight flexible metallic tubing | 16. Cable trays* |
| 7. Liquid-tight flexible non-metallic tubing | 17. Cablebus |
| 8. Metallic surface raceway* | 18. Flexible metallic conduit* |
| 9. Wooden surface raceway* | 19. Electrical non-metallic tubing |
| 10. Non-metallic surface raceway* | 20. Multi-outlet assembly |

** The most commonly used methods done by practitioners*

WIRING METHODS

Conductors of Different Systems

- a) **600 Volts, Nominal, or Less** - AC circuit and DC conductors shall be permitted to occupy the same equipment wiring enclosure, cable, or raceway. All conductors shall have an insulating rating equal at least the maximum circuit voltage applied to any conductor.
- b) **Over 600 Volts Nominal** - Conductors rated over 600V, shall not occupy the same equipment wiring enclosure, cable, or raceway unless permitted. The following listed are permitted to be in the same path:
 1. Secondary wiring to electric-discharge lamps of 1000 volts or less.
 2. Primary leads of electric-discharge lamp ballast.
 3. Excitation, control, relay, and ammeter conductors used in individual motor or starter.
 4. Motor, switchgear and control assemblies, and of similar equipment conductors.
 5. In manholes, cond. of each system is permanently & effectively separated from other system.

Protection against Physical Damage

- Either exposed and concealed locations, installed in joists, rafters, or wood members. Holes must not less than 30 mm of the nearest edge. Screw penetrations, nails by a steel plate or bushing shall be at least 1.60 mm thick.

a) **Cable and Raceways Through Wood Members**

1. Bored Holes
2. Notches in Wood

b) **Nonmetallic-Sheathed Cables, Electrical Nonmetallic Tubing through Metal Framing Members**

1. Nonmetallic-Sheathed Cable - protected by listed bushing, grommets covering all metal edges.
2. Nonmetallic-Sheathed Cable and Electrical Nonmetallic Tubing

- c) **Cables Through Spaces Behind Panels Designed to Allow Access**
- d) **Cables and Raceways Parallel to Framing Members and Furring Strips**
- e) **Cables and Raceways Installed in Shallow Grooves**
- f) **Insulated Fittings** - Raceways containing ungrounded conductors 22 mm² or larger enter a cabinet, enclosure, or raceway, protected by substantial fitting with a smoothly rounded insulating surface.

Mechanical and Electrical Continuity - Conductors

- ✓ Conductors in raceways shall be continuous between outlets, boxes, devices, and so forth. There shall be no splice or tap within a raceway unless permitted.
- ✓ In multiwire branch circuits, the continuity of a grounded conductor shall not depend on device connections such as lampholders, receptacles, and so forth, where the removal of such devices would interrupt the continuity.

Length of Free Conductors at Outlets, Junctions, and Switch Points

- At least 150 mm of free conductor from the point in the box to the raceway or cable sheath at each outlet, junction, and switch point for splices.

Wiring in Ducts, Plenums, and Other Air-Handling Spaces

- The following are listed types of material that are permitted for wirings in ducts, plenums, air-handling spaces:

1. Type MI cable, Type MC cable without non-metallic covering.
2. EMT, FMT, IMC, or RMC without non-metallic covering.

Panels Designed to Allow Access

- Cables, raceways, and equipment installed behind panels designed to allow access, including suspended ceiling panels, shall be arranged and secured so as to allow the removal of panels and access to the equipment.

Requirements for Over 600 Volts, Nominal

Conductor Bending Radius:

1. Nonshielded Conductors - The bending radius shall not be less than 8 times the overall diameter.
2. Shielded or Lead Covered Conductor - The bending radius shall be 12 times the overall diameter.
3. Multiconductor or Multiplexed Single Conductor - 12 times the diameter of individual conductor or 7 times the overall diameter, whichever is greater.

CONDUCTORS FOR GENERAL WIRING

Stranded Conductors

- The conductors installed in raceways, size 8.0 mm² and larger shall be stranded.

Conductors in Parallel

- Conductors that are 50 mm² and larger (aluminum, copper-clad aluminum, copper) are permitted to be in parallel. Parallel conductors in each phase, polarity, neutral/grounded circuit conductors shall comply with the ff:

1. Be the same length
2. Have the same conductor material
3. Be the same cross sectional area of the conducting material
4. Have the same insulation type
5. Be terminated in the same manner

Shielded

- Solid dielectric insulated conductors operated above 2000 volts in permanent installations shall have an ozone resistant insulation and shall be shielded.

Locations

- a) **Dry Locations** - Insulated conductors and cables of any type can be used in dry locations.
- b) **Dry and Damp Locations** - Insulated conductors and cables used in dry and damp locations shall be of Types FEP, FEPB, MTW, PFA, RHH, RHW, RHW-2, SA, THHN, THW, THW-2, THHW, THHW-2, THWN, THWN-2, TW, XHH, XHHW, XHHW-2, Z, or ZW
- c) **Wet Locations** - Conductors used in wet locations shall be:
 1. Moisture-impervious metal sheathed
 2. Types MTW, RHW, RHW-2, TW, THW, THW-2, THHW, THHW-2, THWN, THWN-2, XHHW, XHHW-2, ZW
- d) **Locations Exposed to Direct Sunlight** - Insulated conductors or cables exposed to direct rays of the sun shall be of types that are sunlight resistant.

Marking

- a) **Required Information** - All conductors and cables shall be marked with the following:
 1. The maximum rated voltage.
 2. Proper type of letter or letters.
 3. The manufacturer's name, trademark, or distinctive marking of manufacturer.
 4. Size in millimeter square or millimeter diameter.
 5. Cable assemblies where the neutral conductor is smaller than the ungrounded conductors.
- b) **Method of Marking**
 1. **Surface Marking** - The size in mm² or mm diameter shall be repeated at intervals not exceeding 600 mm. All other markings shall be repeated at intervals not exceeding 1000 mm.
 - Single-conductor and Multiconductor rubber and thermoplastic insulated wire
 - Nonmetallic-sheathed cable
 - Service-entrance cable
 - Underground feeder and branch-circuit cable
 - Tray cable
 - Irrigation cable
 - Power-limited tray cable
 - Instrumentation tray cable
 2. **Marker Tape** - Metal-covered multiconductor cables shall employ a marker tape.
 3. **Tag Marking** - Printed tag shall be attached to the coil, reel or carton for the following:
 - Mineral-insulated, metal-sheathed cable
 - Switchboard wires
 - Metal-covered, single-conductor cables
 - Type AC cable
- c) **Suffixes to Designate Number of Conductors** - A type letter to indicate the number of conductors.
 - D - Two insulated conductors lay parallel with nonmetallic covering.
 - M - Assembly of two or more insulated conductors, twisted spirally with nonmetallic covering.

Aluminum Conductor Material

- All aluminum alloy conductors shall be made of AA-8000 series electrical grade aluminum.

1. Solid Conductors - 8.0 mm² (3.2 mm dia.), 5.5 mm² (2.6 mm dia.), and 3.5 mm² (2.0 mm dia.)
2. Stranded Conductors - 8.0 mm² through 500 mm² (Type RHH, RHW, XHHW, THW, THHW, THWN, THHN, service-entrance TYPE SE Style U and SE Style R)

Table 3.0.1.5 Minimum Cover Requirements, 0 to 600 Volts, Nominal, Burial in Millimeters

Location of Wiring Method or Circuit	Type of Wiring Method or Circuit				
	Column 1 Direct Burial Cables or Conductors (mm)	Column 2 Rigid Metal Conduit or Intermediate Metal Conduit (mm)	Column 3 Nonmetallic Raceways Listed for Direct Burial Without Concrete Encasement or Other Approved Raceways (mm)	Column 4 Residential Branch Circuits Rated 120 Volts or Less with GFCI Protection and Maximum Overcurrent Protection of 20 Amperes (mm)	Column 5 Circuits for Control of Irrigation and Landscape Lighting Limited to Not More Than 30 Volts and Installed with Type UF or in Other Identified Cable or Raceway (mm)
All locations not specified below	600	150	450	300	150
In trench below 50 mm thick concrete or equivalent	450	150	300	150	150
Under a building	0 (in raceway only)	0	0	0 (in raceway only)	0 (in raceway only)
Under minimum of 100 mm thick concrete exterior slab with no vehicular traffic and the slab extending not less than 150 mm beyond the underground installation	450	100	100	150 (direct burial) 100 (in raceway)	150
Under minimum of 100 mm thick concrete exterior slab with no vehicular traffic and the slab extending not less than 150 mm beyond the underground installation	450	100	100	150 (direct burial) 100 (in raceway)	150
Under streets, highways, roads, alleys, driveways, and parking lots	600	600	600	600	600
One- and two-family dwelling driveways and outdoor parking areas, and used only for dwelling-related purposes	450	450	450	450	450
In or under airport runways, including adjacent areas where trespassing prohibited	450	450	450	450	450

Notes:

1. Cover is defined as the shortest distance in millimeters (inches) measured between a point on the top surface of any direct-buried conductor, cable, conduit, or other raceway and the top surface of finished grade, concrete, or similar cover.
2. Raceways approved for burial only where concrete encased shall require concrete envelope not less than 50 mm thick.
3. Lesser depths shall be permitted where cables and conductors rise for terminations or splices or where access is otherwise required.
4. Where one of the wiring method types listed in Columns 1–3 is used for one of the circuit types in Columns 4 and 5, the shallowest depth of burial shall be permitted.
5. Where solid rock prevents compliance with the cover depths specified in this table, the wiring shall be installed in metal or nonmetallic raceway permitted for direct burial. The raceways shall be covered by a minimum of 50 mm of concrete extending down to rock.

Table 3.0.2.20 Minimum Cover¹ Requirements

Circuit Voltage	General Conditions (not otherwise specified)			Special Conditions (use if applicable)		
	(1) Direct-Buried Cables (mm)	(2) Rigid Nonmetallic Conduit ² (mm)	(3) Rigid Metal Conduit and Intermediate Metal Conduit (mm)	(4) Raceways under buildings or exterior concrete slabs, 100mm minimum thickness ³ (mm)	(5) Cables in airport runways or adjacent areas where trespass is prohibited (mm)	(6) Areas subject to vehicular traffic, such as thoroughfares and commercial parking areas (mm)
Over 600 V through 22 kV	760	460	150	100	450	600
Over 22 kV through 40 kV	900	600	150	100	450	600
Over 40 kV	1000	760	150	100	450	600

Table 3.10.1.13 Conductor Application and Insulations

Trade Name	Type Letter	Maximum Operating Temperature	Application Provisions	Insulation	Thickness of Insulation (mm)		Outer Covering ¹
Fluorinated ethylene propylene	FEP or FEPB	90°C 194°F	Dry and damp locations	Fluorinated ethylene propylene	0.51	0.76	None
		200°C 392°F	Dry locations — special applications ²	Fluorinated ethylene propylene	0.36	0.36	Glass braid
							Glass or other suitable braid material
Mineral insulation (metal sheathed)	MI	90°C 194°F	Dry and wet locations For special applications ²	Magnesium oxide	0.58		Copper or alloy steel
		250°C 482°F			0.91		
					1.27		
Moisture-, heat-, and oil-resistant thermoplastic	MTW	60°C 140°F	Machine tool wiring in wet locations	Flame-retardant moisture-, heat-, and oil-resistant thermoplastic	(a) 0.76	(b) 0.38	(a) None (b) Nylon jacket or equivalent
		90°C 194°F	Machine tool wiring in dry locations. FPN: See NFPA 79.		0.76	0.51	
					1.14	0.76	
					1.52	0.76	
					1.52	1.02	
					2.03	1.27	
					2.41	1.52	
Paper		85°C 185°F	For underground service conductors, or by special permission	Paper			Lead sheath
Perfluoro-alkoxy	PFA	90°C 194°F	Dry and damp locations	Perfluoro-alkoxy	0.51		None
		200°C 392°F	Dry locations — special applications ²		0.76		
					1.14		
Perfluoro-alkoxy	PFAH	250°C 482°F	Dry locations only. Only for leads within apparatus or within raceways connected to apparatus (nickel or nickel-coated copper only)	Perfluoro-alkoxy	0.51		None
					0.76		
					1.14		
Thermoset	RHH	90°C 194°F	Dry and damp locations		1.14		Moisture-resistant, flame-retardant, nonmetallic covering ¹
					1.52		
					2.03		
					2.41		
					2.79		
					3.18		
Moisture-resistant thermoset	RHW ⁴	75°C 167°F	Dry and wet locations	Flame-retardant, moisture-resistant thermoset	1.14		Moisture-resistant, flame-retardant, nonmetallic covering ⁵
					1.52		
					2.03		
					2.41		
					2.79		
					3.18		
Moisture-resistant thermoset	RHW-2	90°C 194°F	Dry and wet locations	Flame-retardant moisture-resistant thermoset	1.14		Moisture-resistant, flame-retardant, nonmetallic covering ⁵
					1.52		
					2.03		
					2.41		
					2.79		
					3.18		
Silicone	SA	90°C 194°F	Dry and damp locations	Silicone rubber	1.14		Glass or other suitable braid material
		200°C 392°F	For special application ²		1.52		
					2.03		
					2.41		
					2.79		
					3.18		

Moisture- and heat-resistant thermoplastic	THW ⁴	75°C 167°F 90°C 194°F	Dry and wet locations Special applications within electric discharge lighting equipment. Limited to 1000 open-circuit volts or less. (size 14-8 only as permitted in 410.33)	Flame-retardant, moisture- and heat-resistant thermoplastic	0.76 1.14 1.52 2.03 2.41 2.79 3.18	None
Moisture- and heat-resistant thermoplastic	THWN ⁴	75°C 167°F	Dry and wet locations	Flame-retardant, moisture- and heat-resistant thermoplastic	0.38 0.51 0.76 1.02 1.27 1.52 1.78	Nylon jacket or equivalent
Moisture-resistant thermoplastic	TW	60°C 140°F	Dry and wet locations	Flame-retardant, moisture-resistant thermoplastic	0.76 1.14 1.52 2.03 2.41 2.79 3.18	None
Thermoset	SIS	90°C 194°F	Switchboard wiring only	Flame-retardant thermoset	0.76 1.14 2.41	None
Thermoplastic and fibrous outer braid	TBS	90°C 194°F	Switchboard wiring only	Thermoplastic	0.76 1.14 1.52 2.03	Flame-retardant, nonmetallic covering
Extended polytetrafluoroethylene	TFE	250°C 482°F	Dry locations only. Only for leads within apparatus or within raceways connected to apparatus, or as open wiring (nickel or nickel-coated copper only)	Extruded polytetra-fluoroethylene	0.51 0.76 1.14	None
Heat-resistant thermoplastic	THHN	90°C 194°F	Dry and damp locations	Flame-retardant, heat-resistant thermoplastic	0.38 0.51 0.76 1.02 1.27 1.52 1.78	Nylon jacket or equivalent
Moisture- and heat-resistant thermoplastic	THHW	75°C 167°F 90°C 194°F	Wet location Dry location	Flame-retardant, moisture- and heat-resistant thermoplastic	0.76 1.14 1.52 2.03 2.41 2.79	None

Underground feeder and branch-circuit cable — single conductor (for Type UF cable employing more than one conductor, see Article 3.40.)	UF	60°C 140°F 75°C 167°F ⁷	See Article 3.40.	Moisture-resistant Moisture- and heat-resistant	1.52 2.03 2.41	Integral with insulation
Underground service-entrance cable — single conductor (for Type USE cable employing more than one conductor, see Article 3.38.)	USE ⁴	75°C 167°F	See Article 3.38.	Heat- and moisture-resistant	1.14 1.52 2.03 2.41 2.79 3.18	Moisture-resistant nonmetallic covering (See 3.38.1.2.)
Thermoset	XHH	90°C 194°F	Dry and damp locations	Flame-retardant thermoset	0.76 1.14 1.40 1.65 2.03 2.41	None
Moisture-resistant thermoset	XHHW ⁴	90°C 194°F 75°C 167°F	Dry and damp locations Wet locations	Flame-retardant, moisture-resistant thermoset	0.76 1.14 1.40 1.65 2.03 2.41	None
Moisture-resistant thermoset	XHHW-2	90°C 194°F	Dry and wet locations	Flame-retardant, moisture-resistant thermoset	0.76 1.14 1.40 1.65 2.03 2.41	None
Modified ethylene tetrafluoro-ethylene	Z	90°C 194°F 150°C 302°F	Dry and damp locations Dry locations — special applications ²	Modified ethylene tetrafluoro-ethylene	0.38 0.51 0.64 0.89 1.14	None
Modified ethylene tetrafluoro-ethylene	ZW ⁴	75°C 167°F 90°C 194°F 150°C 302°F	Wet locations Dry and damp locations Dry locations — special applications ²	Modified ethylene tetrafluoro-ethylene	0.76 1.14	None

Number of Current-Carrying Conductors	Percentage Values (Derating Factor)
1-3	100%
4-6	80%
7-9	70%
10-20	50%
21-30	45%
31-40	40%
41 and above	35%

Conductor mm ²		Service or Feeder Rating (Amperes)
Copper	Aluminum or Copper-Clad Aluminum	
22	30	100
30	30	110
30	50	125
38	60	150
50	80	175
60	100	200
80	125	225
100	150	250
125	175	300
175	250	350
200	325	400

Table 3.10.1.16 Allowable Ampacities of Insulated Conductors Rated 0 Through 2000 Volts, 60°C Through 90°C (140°F Through 194°F), Not More Than Three Current-Carrying Conductors in Raceway, Cable, or Earth (Directly Buried), Based on Ambient Temperature of 30°C (86°F)

Size mm ² (mm dia.)	Temperature Rating of Conductor (See Table 3.10.1.13.)						Size mm ² (mm dia.)
	60°C (140°F)	75°C (167°F)	90°C (194°F)	60°C (140°F)	75°C (167°F)	90°C (194°F)	
	Types TW, UF	Types RHW, THHW, THW, THWN, XHHW, USE, ZW	Types TBS, SA, SIS, FEP, FEPB, MI, RHH, RHW-2, THHN, THHW, THW-2, THWN-2, USE-2, XHH, XHHW, XHHW-2, ZW-2	Types TW, UF	Types RHW, THHW, THW, THWN, XHHW, USE, ZW	Types TBS, SA, SIS, FEP, FEPB, MI, RHH, RHW-2, THHN, THHW, THW-2, THWN-2, USE-2, XHH, XHHW, XHHW-2, ZW-2	
	COPPER			ALUMINUM OR COPPER-CLAD ALUMINUM			
2.0(1.6)*	20	20	25	—	—	—	2.0(1.6)*
3.5(2.0)*	25	25	30	20	20	25	3.5(2.0)*
5.5(2.6)*	30	35	40	25	30	35	5.5(2.6)*
8.0(3.2)	40	50	55	30	40	45	8.0(3.2)
14	55	65	70	40	50	60	14
22	70	85	90	55	65	80	22
30	90	110	115	65	80	90	30
38	100	125	130	75	90	105	38
50	120	145	150	95	110	125	50
60	135	160	170	100	120	135	60
80	160	195	205	120	145	165	80
100	185	220	225	140	170	190	100
125	210	255	265	165	200	225	125
150	240	280	295	185	225	250	150
175	260	305	345	205	245	275	175
200	280	330	355	220	265	300	200
250	315	375	400	255	305	345	250
325	370	435	470	305	365	410	325
375	395	470	530	315	380	430	375
400	405	485	515	335	405	460	400
500	445	540	580	370	440	495	500
CORRECTION FACTORS							
Ambient Temp. (°C)	For ambient temperatures other than 30°C (86°F), multiply the allowable ampacities shown above by the appropriate factor shown below.						Ambient Temp. (°F)
21-25	1.08	1.05	1.04	1.08	1.05	1.04	70-77
26-30	1.00	1.00	1.00	1.00	1.00	1.00	78-86
31-35	0.91	0.94	0.96	0.91	0.94	0.96	87-95
36-40	0.82	0.88	0.91	0.82	0.88	0.91	96-104
41-45	0.71	0.82	0.87	0.71	0.82	0.87	105-113
46-50	0.58	0.75	0.82	0.58	0.75	0.82	114-122
51-55	0.41	0.67	0.76	0.41	0.67	0.76	123-131
56-60	—	0.58	0.71	—	0.58	0.71	132-140
61-70	—	0.33	0.58	—	0.33	0.58	141-158
71-80	—	—	0.41	—	—	0.41	159-176

CABINETS, CUTOOT BOXES, AND METER SOCKET ENCLOSURES

Installation (Surface Type Enclosures)

- a) **Damp Locations** - Enclosures installed in damp locations shall prevent moisture from entering and shall be placed with at least 6 mm airspace from the wall or of a supporting surface.
- b) **Wet Locations** - Enclosures installed in wet locations shall be weatherproof and shall be placed with at least 6 mm airspace from the wall or of a supporting surface.
- c) **Position in Wall** - Enclosures shall be installed in walls of concrete, tile, or other noncombustible material. Cabinets shall be installed so that the front edge is not set back of the finished surface for more than 6 mm.

Enclosures for Switches or Overcurrent Devices

1. Shall not be used as junction boxes, auxiliary gutters, or raceways for feeder conductors unless adequate space is provided for this purpose.
2. The conductors shall not fill the wiring space at any cross section to more than 40%.
3. Taps shall not fill the wiring space at any cross section to more than 75%.

Construction Specifications (Cabinets, Cutout Boxes, and Meter Socket Enclosures)

- a) **Strength** - The materials to be used shall have ample strength and rigidity to support the electrical components. If constructed of sheet steel, metal thickness shall not be less than 1.35 mm uncoated.
- b) **Spacing** - Spacings shall be sufficient to provide ample room for the distribution of wires and cables.
 1. **Base** - Airspace of at least 1.60 mm between the base of the device and the wall of any cabinet.
 2. **Doors** - There shall be airspace of at least 25 mm between any live metal parts.
 3. **Live Parts** - Airspace of at least 13 mm between the walls, back, and gutter partition. Spacing shall be increased to at least 25 mm for voltages of 251 to 600, nominal.

OUTLET, DEVICE, PULL, AND JUNCTION BOXES; CONDUIT BODIES; FITTINGS; AND HANDHOLE ENCLOSURES

Round Boxes

- Round boxes shall not be used where conduits requires the use of locknuts/bushings on the side of the box.

Nonmetallic Boxes

- Are permitted only with open wiring on insulators, concealed knob-and-tube wiring, cabled wiring methods with entirely nonmetallic sheaths, flexible cords, and non metallic raceways.

Short -Radius Conduit Bodies

- Capped-elbows and service-entrance elbows that enclose conductors 14 mm² or smaller shall not contain splices, taps, or devices and have sufficient size to provide space.

Supports for Enclosures:

- a) **Surface Mounting** - Enclosures surface mounted shall be rigidly and securely fastened in place.
- b) **Structural Mounting**- Rigidly supported either by directly using a metal, polymeric, or wood brace.
 1. **Nails and Screws** - Shall be 6 mm of back or ends of the enclosure.
 2. **Braces**
 - Metal Braces - Protected against corrosion and not less than 0.50 mm thick uncoated.
 - Wood Braces - Cross section not less than 25 mm x 50 mm.
 - Polymeric Braces - Must be identified to be suitable for use.
- c) **Mounting in Finished Surfaces** - Enclosures shall be supported by clamps, anchors, or fittings

- d) **Suspended Ceilings** - The suspended ceilings shall not be more than 1650 cm³ in size and has the enclosure fastened securely.
 - Framing Members - fastened to the framing members by bolts, screws, or rivets
- e) **Raceway Supported Enclosure, Without Devices, Luminaires (Fixtures), or Lampholders** - Raceways shall not exceed 1650 cm³ in size. Two or more conduits threaded wrench tight supports the enclosure. Each conduit shall be 900 mm within the enclosure, or 450 mm of the enclosure if on the same side.
- f) **Raceway Supported Enclosures, with Devices, Luminaires (Fixtures), or Lampholders** - Raceway shall not exceed 1650 cm³ in size, and secured by wrench tight conduits 450 mm within of the enclosure.
- g) **Enclosures in Concrete or Masonry** - Enclosures shall be protected from corrosion and securely embedded.
- h) **Pendant Boxes** - Can be supported by flexible cord or conduits with length of 450 mm.

Outlet Boxes

- a) **Depth of Outlet Boxes**
 - Internal depth - Not less than 13 mm.
 - Boxes enclosing flush devices - Internal depth of not less than 24 mm.
- b) **Maximum Luminaire (Fixture) Weight** - Outlet boxes shall be permitted to support 23 kg or less. A luminaire more than 23 kg shall be supported independently.
- c) **Boxes at Ceiling-Suspended (Paddle) Fan Outlets** - Outlet boxes as the sole support of a ceiling-suspended (paddle) fan shall be listed. Outlets shall not support more than 32 kg. Outlets designed to support fans weighing 16 kg or more, markings shall include the maximum weight to be supported.

Pull and Junction Boxes and Conduit Bodies

1. **Straight Pulls** - The length of the box shall not be less than 8 times the raceway size of the largest raceway.
2. **Angle or U Pulls** - The distance between each raceway entry inside the box and the opposite wall of the box shall not be less than 6 times the raceway size of the largest raceway in a row.

Metal Boxes, Conduit Bodies, and Fittings

- a) **Corrosion Resistant** - Well-galvanized, enameled, properly coated inside and out to prevent corrosion.
- b) **Thickness of Metal**
 - Sheet steel boxes not over 1650 cm³ shall be made from steel not less than 1.60 mm thick.
 - The wall of malleable iron box/conduit body and a die-cast or permanent-mold cast aluminum, brass, bronze, or zinc box or conduit body shall not be less than 2.40 mm thick.
 - Other cast metal boxes or conduit bodies shall have a wall thickness not less than 3 mm.

Pull and Junction Boxes for Use on Systems Over 600 Volts, Nominal

1. **Straight Pulls** - The length of the box shall not be less than 48 times the outside diameter, over sheath, of the largest shielded or lead-covered conductor or cable entering the box.
2. **For Angle or U Pulls** - The distance between each cable and conductor shall not be less than 36 times the outside diameter, over sheath, of the largest cable or conductor.

ARMORED CABLE: TYPE AC

Armored Cable - A fabricated assembly of insulated conductors in a flexible metallic enclosure.

- ✓ **Thermal Insulation** - 90°C (194°F); For Application usage 60°C (140°F)
- ✓ **Bending Radius** - The radius of the curve not less than 5 times the diameter.
- ✓ **Securing** - 300 mm within every outlet box, junction box, cabinet.
- ✓ **Supporting** - Horizontal run supported within 1400m intervals.

Uses Permitted	Uses Not Permitted
In both exposed and concealed works	Where subject to physical damage
In cable trays	In damp or wet locations
In dry locations	Where exposed to corrosive fumes or vapors
Embedded in plaster finish on brick or other masonry; except in damp or wet locations	Embedded in plaster finish on brick or other masonry in damp or wet locations
To be run or fished in the air voids of masonry block or tile walls; not exposed to excessive moisture/dampness	In air voids of masonry block or tile walls where walls are exposed or subject to excessive moisture/dampness

INTEGRATED GAS SPACER CABLE: TYPE IGS

Integrated Gas Spacer - A factory assembly of one or more conductors, each individually insulated and enclosed in a loose fit, nonmetallic flexible conduit as an integrated gas spacer cable rated 0 through 600V.

- ✓ **Bends** - A run Type IGS shall not contain more than equivalent of four quarter bends. (360 bends)
- ✓ **Fittings** - The terminations and splices shall be suitable for maintaining gas pressure within the conduit. Valve and cap shall be provided to check the gas pressure or to inject gas into the conduit
- ✓ **Conductors** - Solid aluminum rods, lay parallel, consisting of 1 to 19 (13 mm diam. rods). The minimum size conductor size shall be 125 mm², and the maximum size shall be 2375 mm². (4750 kcmil)
- ✓ **Insulation** - Shall be dry kraft paper tapes and a pressurized sulfur hexafluoride (SF₆). The nominal gas pressure shall be 138 kPA gauge.
- ✓ **Conduit** - The conduit shall be a medium density polyethylene identified as suitable for use with natural gas rated pipe in race size 50 mm, 80 mm, or 100 mm.

Uses Permitted	Uses Not Permitted
Service-entrance conductors	Interior wiring or be exposed in contact with buildings
Feeder or branch-circuit conductors	

FLAT CABLE ASSEMBLIES: TYPE FC

Flat Cable Assemblies - An assembly of parallel conductors formed integrally with an insulating material web specifically for field installation in surface metal raceway.

- ✓ **Construction** - It consist of 2, 3, 4, or 5 conductors.
- ✓ **Conductors** - 5.5 mm² (2.6 mm dia.) special stranded copper wires.
- ✓ **Securing and Supporting** - Supported by special design features within surface metal raceways.
- ✓ **Temperature Rating** - The ratings shall be marked on the surface at intervals not exceeding 600 mm.
- ✓ **Grounded Conductor** - White or gray marking.

Uses Permitted	Uses Not Permitted
Branch circuits for lighting, small appliances, or small power loads (not exceed 30 amperes)	Subject to corrosive vapors unless suitable for application
Installed for exposed work	In hoistways or on elevators or escalators
Not subject to physical damage.	In any hazardous (location)
Surface metal raceways identified for the use	Outdoors in wet or damp locations

FLAT CONDUCTOR CABLE: TYPE FCC

Flat Conductor Cable - 3 or more flat copper conductors placed edge-to-edge and separated and enclosed within an insulating assembly.

Bottom Shield - The protective layer installed between the floor and Type FCC for protection

Top Shield - A grounded metal shield covering under-carpet components.

Cable Connector - Connector designed to join Type FCC without using a junction box.

FCC System - Complete wiring system for branch circuits design for installation under carpet squares.

Insulating End - Insulator designed to electrically insulate the end of Type FCC.

Metal Shield Connections - Means of connection designed to electrically and mechanically connect a metal shield to another metal.

Transition Assembly - Incorporated with electrical connection and a suitable box or covering for safety.

- ✓ **Voltage** - Shall not exceed 300V and voltage between phase and ground conductors not exceed 150V.
- ✓ **Current** - General-purpose and appliance branch circuits shall have 20A rating. And, individual branch circuits shall have 30 ampere rating.

Installation (shall be permitted on the following conditions):

- a) **Floors** - Hard, sound, smooth, continuous floor surfaces made of concrete, ceramic/composition flooring.
- b) **Walls** - Wall surfaces in surface metal raceways.
- c) **Damp Locations**
- d) **Heated Floors** - Shall be identified if in excess of 30°C
- e) **System Height** - Exceeding 2.30 mm shall be tapered or feathered at the edges to floor level.
- f) **Coverings** - Covered with carpet squares not larger than 900 mm square.

Uses Not Permitted
Outdoors or in wet locations
Subject to corrosive vapors
In any hazardous (classified) location
In residential, school, and hospital buildings

MEDIUM VOLTAGE CABLE: TYPE MV

Medium Voltage Cable - A single or multiconductor solid dielectric insulated cable rated 2001V or higher. Medium voltage cable shall be constructed with copper, aluminum, copper-clad aluminum conductors

Uses Permitted	Uses Not Permitted
In wet or dry locations	Where exposed to direct sunlight
In raceways	In cable trays
In cable trays (specified)	Direct burial (not in accordance with code)
Direct burial (specified)	
In messenger supported wiring	

SERVICE-ENTRANCE CABLE: TYPES SE AND USE

Service-Entrance Cable - A single conductor or multiconductor assembly provided with or without an overall covering, primarily used for services, and of the following types:

- a) **Type SE** - Cable with flame-retardant, moisture-resistant covering.
 - b) **Type USE** - Cable identified for underground use, having a moisture-resistant covering, but not required to have a flame-retardant covering.
- ✓ **Bending Radius** - The radius of the curve of the inner edge shall not be less than 5 times the diameter of the cable.

METAL-CLAD CABLE: TYPE MC

Metal Clad Cable - A factory assembly of one or more insulated circuit conductors with or without optical fiber members enclosed in an armor of interlocking metal tape or a smooth or corrugated metallic sheath.

- ✓ **Uses Permitted** - Type MC cable shall be permitted as follows:
1. For services, feeders, and branch circuits
 2. For power, lighting, control, and signal circuits
 3. Indoors or outdoors
 4. Exposed or concealed
 5. To be direct buried where identified for such use
 6. In cable tray where identified for such use
 7. In any raceway
 8. As aerial cable on a messenger
 9. In hazardous (classified) locations as permitted
 10. In dry locations and embedded in plaster finish on brick except in damp or wet locations
 11. In wet locations where any of the following conditions are met:
 - Metallic covering is impervious to moisture
 - A lead sheath or moisture-impervious jacket is provided under the metal covering
 - The insulated conductors under the metallic covering are listed for use in wet locations
 12. Where single-conductor cables are used, all phase conductors and, where used, the neutral conductor shall be grouped together
- ✓ **Uses Not Permitted** - shall not be exposed to corrosive conditions
1. Where subject to physical damage
 2. Direct burial in the earth
 3. In concrete
- ✓ **Bending Radius** - The radius of the curve of the inner edge of bends shall not be less than the required:
- **Smooth Sheath**
 - Cable not more than 19 mm dia. - 10 times the external diameter
 - Cable more than 19 mm but less than 40 mm dia. - 12 times the external diameter
 - Cable more than 40 mm dia. - 15 times the external diameter
 - **Interlocked-Type Armor or Corrugated Sheath** - 7 times the external diameter
 - **Shielded Conductors** - 12 times the overall diameter of one of the individual conductors or 7 times the overall diameter of the multiconductor cable, whichever is greater.
- ✓ **Securing** - Unless otherwise provided, cables shall be secured at intervals not exceeding 1800 mm. 4 or fewer conductors sized no larger than 5.5 mm² (2.6 mm dia.) shall be secured within 300 mm.
- ✓ **Conductors** - copper, aluminum, or copper-clad aluminum, solid or stranded. The minimum conductor size shall be 18 AWG (0.75 mm²; 1.0 mm dia.) copper and 3.5 mm² (2.0 mm dia.) aluminum or copper-clad aluminum.

MINERAL-INSULATED, METAL-SHEATHED CABLE: TYPE MI

Mineral Insulated, Metal-Sheathed Cable - A factory assembly of one or more conductors insulated with a highly compressed refractory mineral insulation and enclosed in a liquidtight and gastight continuous copper or alloy steel sheath.

- ✓ **Conductors** - Solid copper, nickel, or nickel-coated copper
- ✓ **Uses Permitted** - Type MI cable shall be permitted as follows:
 1. For services, feeders, and branch circuits
 2. For power, lighting, control, and signal circuits
 3. In dry, wet, or continuously moist locations
 4. Indoors or outdoors
 5. Where exposed or concealed
 6. Where embedded in plaster, concrete, fill, or other masonry, whether above or below grade
 7. In any hazardous (classified) location
 8. Where exposed to oil and gasoline
 9. Where exposed to corrosive conditions not deteriorating to its sheath
 10. In underground runs where suitably protected against physical damage and corrosive conditions
 11. In or attached to cable tray
- ✓ **Uses Not Permitted** - Type MI cable shall not be used under the following conditions
 1. Underground runs unless protected from physical damage, where necessary
 2. Exposed to conditions that are destructive and corrosive to the metallic sheath
- ✓ **Bending Radius** - The radius of the curve of the inner edge of bends shall not be less than the required
 - Cable more than 19 mm dia. - 5 times the external diameter
 - Cable greater than 19 mm but not more than 25 mm dia. - 10 times the external diameter
- ✓ **Securing** - Cables shall be secured at intervals not exceeding 1800 mm

POWER AND CONTROL TRAY CABLE: TYPE TC

Power and Control Tray Cable - A factory assembly of two or more insulated conductors, with or without associated bare or covered grounding conductors, under a nonmetallic jacket.

- ✓ **Uses Permitted** - Type TC cable shall be permitted to be used as follows:
 1. For power, lighting, control, and signal circuits
 2. In cable trays
 3. In raceways
 4. In outdoor locations supported by a messenger wire
 5. For Class 1 circuits
 6. For non-power-limited fire alarm circuits
 7. In industrial establishments where there is regular maintenance and supervision.
 8. Where installed in wet locations and shall be resistant to moisture and corrosive agents.
- ✓ **Uses Not Permitted** - Type TC tray cable shall not be installed as follows:
 1. Exposed to physical damage
 2. Installed outside a raceway or cable tray system, except as permitted.
 3. Exposed to direct rays of the sun, unless identified as sunlight resistant.
 4. Direct buried, unless identified for such use.
- ✓ **Bending Radius** - Type TC cable without metal shielding, bending radius shall be as follows:
 - 25 mm or less in dia. cable - 4 times the overall diameter
 - Larger than 25 mm (1 in.) but not more than 50 mm dia. - 5 times the overall diameter
 - Larger than 50 mm in dia. - 6 times the overall diameter

Type TC cables with metallic shielding shall have a minimum bending radius of not less than 12 times the cable overall diameter

NONMETALLIC-SHEATHED CABLE: TYPES NM, NMC, AND NMS

Nonmetallic-Sheathed Cable - A factory assembly of two or more insulated conductors enclosed within an overall nonmetallic jacket.

Type NM - Insulated conductors enclosed within an overall nonmetallic jacket.

Type NMC - Insulated conductors enclosed within an overall, corrosion resistant, nonmetallic jacket.

Type NMS - Insulated power or control conductors with signaling, data, and communications conductors within an overall nonmetallic jacket.

- ✓ **Uses Permitted** - Type NM, Type NMC, and Type NMS cables shall be permitted to be used in the ff:
 1. One-and two-family dwellings
 2. Multifamily dwellings permitted to be of Types III, IV, and V construction.
 3. Other structures permitted to be of Types III, IV, and V construction. Cables shall be concealed within walls, floors, or ceilings that provide a thermal barrier of material that has at least a 15-minute finish rating.
 4. Cable trays in structures permitted to be Types III, IV, or V identified for the use.
- ✓ **Uses Not Permitted** - Types NM, NMC, and NMS cables shall not be permitted as follows:
 1. In any dwelling or structure not specifically permitted
 2. Exposed in dropped/suspended ceilings in one-and two-family dwellings
 3. As service-entrance cable
 4. In commercial garages having hazardous (classified) locations
 5. In theaters and similar locations, except permitted
 6. In motion picture studios
 7. In storage battery rooms
 8. In hoistways or on elevators or escalators
 9. Embedded in poured cement, concrete, or aggregate
 10. In hazardous (classified) locations, except permitted
- ✓ **Uses Not Permitted** - Type NM and NMS shall not be used under the ff:
 1. Where exposed to corrosive fumes or vapors
 2. Where embedded in masonry, concrete, adobe, fill, or plaster
 3. In a shallow chase in masonry, concrete, or adobe and covered with plaster, adobe
 4. Where exposed or subject to excessive moisture or dampness
- ✓ **Protection from Physical Damage** - conductors shall be protected by intermediate metallic conduit (IMC), rigid metallic conduit (RMC), electrical metallic tubing (EMT), or Schedule 80 PVC.
- ✓ **Bending Radius** - The radius of the curve of the inner edge shall not be less than 5 times the diameter of the cable.
- ✓ **Securing and Supporting** - The conductors shall be secured by staples, cable ties, straps, hangers, or similar fittings at intervals not exceeding 1400 mm and within 300 mm of every outlet box, junction box, cabinet, etc.
- ✓ **Conductor Insulation** - The conductor temperature insulation must be rated at 90°C
- ✓ **Sheath** - The outer sheath of nonmetallic-sheathed cable shall comply with the ff:
 - a) **Type NM** - Flame retardant and moisture resistant.
 - b) **Type NMC** - Flame retardant, moisture resistant, fungus resistant, and corrosion resistant.
 - c) **Type NMS** - Flame retardant and moisture resistant. The sheath shall be applied so as to separate the power conductors from the communications and signaling conductors.

UNDERGROUND FEEDER AND BRANCH-CIRCUIT CABLE: TYPE UF

Underground Feeder and Branch-Circuit - A factory assembly of one or more insulated conductors with an integral or an overall covering of nonmetallic material suitable for direct burial in the earth.

- ✓ **Uses Permitted** - Type UF cable shall be permitted as follows:
 1. For use underground, including direct burial in the earth
 2. As single-conductor cable
 3. Wiring in wet, dry, or corrosive locations recognized by the code
 4. Installed as nonmetallic-sheathed cable
 5. For solar photovoltaic systems
 6. As single-conductor cables as the non-heating leads for heating cables
 7. Supported by cable trays
- ✓ **Uses Not Permitted** - Type UF cable shall not be used as follows:
 1. As service-entrance cable
 2. In commercial garages
 3. In theaters and similar locations
 4. In motion picture studios
 5. In storage battery rooms
 6. In hoistways or on elevators or escalators
 7. In hazardous (classified) locations
 8. Embedded in poured cement, concrete, or aggregate, except where embedded in plaster as non-heating leads where permitted
 9. Exposed to direct rays of the sun, unless identified as sunlight resistant
 10. Where subject to physical damage
 11. As overhead cable, except where installed as messenger-supported wiring
- ✓ **Bending Radius** - The radius of the curve of the inner edge shall not be less than 5 times the diameter of the cable.
- ✓ **Conductors** - The conductors shall be of sizes 2.0 mm² (1.6 mm dia.) copper or 3.5 mm² (2.0 mm dia.) aluminum or copper-clad aluminum through 100 mm²
- ✓ **Sheath** - The overall covering shall be flame retardant; moisture, fungus, and corrosion resistant; and suitable for direct burial in the earth.

INTERMEDIATE METAL CONDUIT: TYPE IMC

Intermediate Metal Conduit - A steel threadable raceway of circular cross section designed for the physical protection and routing of conductors and cables and for use as an equipment grounding conductor when installed with its integral or associated coupling and appropriate fittings.

- ✓ **Uses Permitted**
 1. **All Atmospheric Conditions and Occupancies** - IMC shall be permitted under all atmospheric conditions and occupancies.
 2. **Corrosion Environments** - IMC, elbows, couplings, and fittings shall be permitted to be installed in concrete, in direct contact with earth.
 3. **Cinder Fill** - IMC shall be protected on all sides by a layer of non-cinder concrete not less than 50 mm thick; where conduit is not less than 450 mm under the fill.
 4. **Wet Locations** - All supports, bolts, straps, screws, and so forth, shall be of corrosion-resistant materials or protected against corrosion by corrosion-resistant materials.
- ✓ **Size**
 - **Minimum** - IMC smaller than raceway size 15 mm shall not be used.
 - **Maximum** - IMC larger than raceway size 100 mm shall not be used.
- ✓ **Bends - Number in One Run** - There shall not be more than 4 quarter bends (360 degree total)

- ✓ **Reaming and Threading** - All cut ends shall be reamed to remove rough edges. Where conduit is threaded in the field, a standard cutting die with a taper of 1 in 16 shall be used.
- ✓ **Securing and Supporting**
 - **Securely Fastened** - 900 mm within of each outlet box, junction box, device box, cabinet, conduit body, or other conduit termination.
 - **Supports** - IMC shall be supported in accordance with one of the following:
 - Conduits supported at intervals not exceeding 3000 mm
 - Exposed vertical risers from industrial machinery or fixed equipment supported at intervals not exceeding 6000 mm.
 - Horizontal runs of IMC supported by openings through framing members at intervals not exceeding 3000 mm and securely fastened within 900 mm.
- ✓ **Marking** - Conduits shall be durably marked at least every 1500 mm with the letters IMC.
- ✓ **Standard Length** - 3000 mm, including an attached coupling and each end shall be threaded.

RIGID METAL CONDUIT: TYPE RMC

Rigid Metal Conduit - A threadable raceway of circular cross section designed for the physical protection and routing of conductors and cables and for use as an equipment grounding conductor when installed with its integral or associated coupling and appropriate fittings. RMC is generally made of steel (ferrous) with protective coatings or aluminum (nonferrous). Special use types are silicon bronze and stainless steel.

- ✓ **Uses Permitted**
 1. **All Atmospheric Conditions and Occupancies** - RMC is permitted under all atmospheric conditions and occupancies. Ferrous raceways and fittings protected from corrosion solely by enamel shall be permitted only indoors not subject to severe corrosive influences.
 2. **Corrosion Environments** - RMC, elbows, couplings, and fittings shall be permitted to be installed in concrete, in direct contact with earth.
 3. **Cinder Fill** - RMC shall be protected on all sides by a layer of non-cinder concrete not less than 50 mm thick; where conduit is not less than 450 mm under the fill.
 4. **Wet Locations** - All supports, bolts, straps, screws, and so forth, shall be of corrosion-resistant materials or protected against corrosion by corrosion-resistant materials.
- ✓ **Size**
 - **Minimum** - RMC smaller than raceway size 15 mm shall not be used.
 - **Maximum** - RMC larger than raceway size 150 mm shall not be used.
- ✓ **Bends - Number in One Run** - There shall not be more than 4 quarter bends. (360 degree total)
- ✓ **Reaming and Threading** - All cut ends shall be reamed to remove rough edges. Where conduit is threaded in the field, a standard cutting die with a taper of 1 in 16 shall be used.
- ✓ **Securing and Supporting**
 - **Securely Fastened** - 900 mm within of each outlet box, junction box, device box, cabinet, conduit body, or other conduit termination.
 - **Supports** - RMC shall be supported in accordance with one of the following:
 - Conduits supported at intervals not exceeding 3000 mm.
 - Exposed vertical risers from industrial machinery or fixed equipment supported at intervals not exceeding 6000 mm.
 - Horizontal runs of RMC supported by openings through framing members at intervals not exceeding 3000 mm and securely fastened within 900 mm.
- ✓ **Marking** - RMC shall be durably marked at least every 3000 mm. Nonferrous conduit of corrosion-resistant material shall have suitable markings.
- ✓ **Standard Length** - 3000 mm, including an attached coupling and each end shall be threaded. Longer or shorter lengths with or without coupling and threaded or unthreaded shall be permitted.

RIGID NONMETALLIC CONDUIT: TYPE RNC

Rigid Nonmetallic Conduit- A nonmetallic raceway of circular cross section, with integral or associated couplings, connectors, and fittings for the installation of electrical conductors and cables.

- ✓ **Uses Permitted** - RNC shall be permitted to be used in the ff:
 1. Concealed - Shall be permitted in walls, floors, and ceilings.
 2. Corrosive influences.
 3. Cinders - RNC shall be permitted in cinder fill.
 4. Wet locations - RNC shall be permitted in portion of dairies, laundries, canneries, or other wet locations and in locations where walls are frequently washed.
 5. Dry and damp locations
 6. Exposed - RNC shall be permitted for exposed work where not subject to physical damage.
 7. Underground installations
 8. Support of conduit bodies
- ✓ **Uses Not Permitted** - RNC shall not be used in the following:
 1. In hazardous (classified) locations - Class 1, Division 2
 2. Support of luminaires (fixtures)
 3. Where subject to physical damage
 4. Ambient temperatures in excess of 50°C unless listed otherwise
 5. Insulation temperature limitations
 6. Theaters and similar locations
- ✓ **Size**
 - **Minimum** - RNC less than raceway size 15 mm shall not be used.
 - **Maximum** - RNC larger than raceway size 150 mm shall not be used.
- ✓ **Trimmings** - All cut ends shall be trimmed inside and outside to remove rough edges.
- ✓ **Securing and Supporting**
 - **Securely Fastened and Supported** - 900 mm within of each outlet, junction, and device box cabinet, conduit body. Fastened so that thermal expansion and contraction is permitted.
- ✓ **Bushings** - Bushing or adapter shall be provided to protect the wire from abrasion.
- ✓ **Marking** - RNC shall be durably marked at least every 3000 mm.

FLEXIBLE METAL CONDUIT: TYPE FMC

Flexible Metal Conduit - A raceway of circular cross section made of helically wound, formed, interlocked metal strip.

- ✓ **Uses Permitted** - FMC permitted to be used in exposed or concealed locations.
- ✓ **Uses Not Permitted** - FMC shall not be used in the following:
 1. Wet locations unless the conductors are approved for the specific condition
 2. In hoistways other than as permitted
 3. In storage battery rooms
 4. In any hazardous (classified) location other than permitted
 5. Exposed to materials with a deteriorating effect on the conductors (such as oil or gasoline)
 6. Underground or embedded in poured concrete or aggregate
 7. Where subject to physical damage
- ✓ **Size**
 - **Minimum** - FMC less than raceway size 15 mm shall not be used.
 - **Maximum** - FMC larger than raceway size 100 mm shall not be used.
- ✓ **Trimmings** - All cut ends shall be trimmed or finished to remove rough edges.
- ✓ **Securing and Supporting**
 - **Securely Fastened and Supported** - 300 mm within of each outlet, junction, and device box cabinet, conduit body, and supported at intervals within 1400 mm.
- ✓ **Couplings and Connectors** - Angle connectors shall not be used for concealed raceway.

LIQUIDTIGHT FLEXIBLE METAL CONDUIT: TYPE LFMC

Liquidtight Flexible Metal Conduit - A raceway of circular cross section having an outer liquidtight, nonmetallic, sunlight-resistant jacket over an inner flexible metal core with associated couplings, connectors, and fittings for the installation of electric conductors.

- ✓ **Uses Permitted** - LFMC shall be permitted to be used in the ff: (exposed or concealed locations)
 1. Operations requiring flexibility/protection from liquids, vapors, or solids.
 2. As permitted in other hazardous (classified) locations (specifically approved)
 3. Direct burial listed and marked for the purpose.
- ✓ **Uses Not Permitted** - LFMC shall not be used in the following:
 1. Where subject to physical damage.
 2. Combination of ambient and conductor temperature in excess of the approved.
- ✓ **Size**
 - **Minimum** - LFMC less than electrical raceway size 15 mm shall not be used
 - **Maximum** - LFMC larger than electrical raceway size 100 mm shall not be used
- ✓ **Securing and Supporting**
 - **Securely Fastened and Supported** - 300 mm within of each outlet, junction, and device box cabinet, conduit body, and supported at intervals within 1400 mm.
- ✓ **Couplings and Connectors** - Angle connectors shall not be used for concealed raceway installations.

HIGH DENSITY POLYETHYLENE CONDUIT: TYPE HDPE CONDUIT

High Density Polyethylene Conduit - A nonmetallic raceway of circular cross section, with associated couplings, connectors, and fittings for the installation of electrical conductors.

- ✓ **Uses Permitted** - HDPE shall be permitted to be used in the ff:
 1. Discrete lengths or in continuous lengths from a reel.
 2. Locations subject to severe corrosive influences, and where subject to chemicals which the materials are specifically approved.
 3. In cinder fill.
 4. In direct burial installation in earth or concrete.
- ✓ **Uses Not Permitted** - HDPE shall not be used in the following:
 1. Where exposed
 2. Within a building
 3. In hazardous (classified) locations, except as permitted.
 4. Ambient temperatures in excess of 50°C unless listed otherwise.
 5. Higher than the listed operating temperature.
- ✓ **Size**
 - **Minimum** - HDPE less than raceway size 15 mm shall not be used.
 - **Maximum** - HDPE larger than raceway size 100 mm shall not be used.
- ✓ **Trimmings** - All cut ends shall be trimmed inside and outside to remove rough edges.
- ✓ **Bushings** - Bushing or adapter shall be provided to protect the wire from abrasion unless the box, fitting, or enclosure design provides equivalent protection.
- ✓ **Marking** - HDPE shall be durably marked at least every 3000 mm. Type of material shall also be included.

NONMETALLIC UNDERGROUND CONDUIT WITH CONDUCTORS: TYPE NUCC

Nonmetallic Underground Conduit with Conductors - A factory assembly of conductors/cables inside a nonmetallic, smooth wall conduit.

- ✓ **Uses Permitted** - NUCC shall be permitted to be used in the ff:
 1. Direct burial underground installations
 2. Encased or embedded in concrete
 3. In cinder fill
 5. In underground locations subject to severe corrosive influences, and where subject to chemicals which the materials are specifically approved.
- ✓ **Uses Not Permitted** - NUCC shall not be used in the following:
 1. In exposed locations
 2. Inside buildings
- ✓ **Size**
 - **Minimum** - NUCC less than raceway size 15 mm shall not be used.
 - **Maximum** - NUCC larger than raceway size 100 mm shall not be used.
- ✓ **Trimmings** - All cut ends shall be trimmed inside and outside to remove rough edges.
- ✓ **Bushings** - Bushing or adapter shall be provided to protect the wire from abrasion unless the box, fitting, or enclosure design provides equivalent protection.
- ✓ **Marking** - NUCC shall be marked at least every 3000 mm including the type of material used.

LIQUIDTIGHT FLEXIBLE NONMETALLIC CONDUIT: TYPE LFNC

Liquidtight Flexible Nonmetallic Conduit - A raceway of circular cross section of various types as follows:

Type LFNC-A - A smooth seamless inner core and cover bonded together and having one or more reinforcement layers between the core and covers.

Type LFNC-B - A smooth inner surface with integral reinforcement within the conduit wall.

Type LFNC-C - A corrugated internal & external surface without integral reinforcement within the conduit.

- ✓ **Uses Permitted** - LFNC shall be permitted to be used in the ff:
 1. Flexibility is required for installation, operation, or maintenance.
 2. Protection for contained conductors is required.
 3. Outdoor locations where listed and marked for the purpose.
 4. Direct burial where listed and marked for the purpose.
 5. Type LFNC-B permitted in lengths longer than 1800 mm.
 6. Type LFNC-B as a prewired assembly, raceway size 15 mm through 25 mm conduits.
- ✓ **Uses Not Permitted** - LFNC shall not be used in the following:
 1. Where subject to physical damage.
 2. Ambient and conductor temperature in excess of that for which LFNC is approved.
 3. In lengths longer than 1800 mm or longer length required degree of flexibility.
 4. Operating voltage in excess of 600V.
 5. In any hazardous (classified) location other than as permitted
- ✓ **Size**
 - **Minimum** - LFNC less than raceway size 15 mm shall not be used.
 - **Maximum** - LFNC larger than raceway size 100 mm shall not be used.
- ✓ **Trimmings** - All cut ends shall be trimmed inside and outside to remove rough edges.
- ✓ **Securing and Supporting** - Type LFNC-B shall be securely fastened and supported with the ff:
 - **Securely Fastened** - At intervals not exceeding 900 mm and within 300 mm.
 - **Supports** - LFNC-B shall be supported in accordance with one of the following:
 - Conduits exceeding 1800 mm in length supported at intervals within 900 mm.
 - Horizontal runs supported by openings through framing members at intervals not exceeding 900 mm and securely fastened within 300 mm.

ELECTRICAL METALLIC TUBING: TYPE EMT

Electrical Metallic Tubing - An unthreaded thin wall raceway of circular cross section designed for the physical protection and routing of conductors and cables and for use as an equipment grounding conductor when installed utilizing appropriate fittings. EMT is generally made of steel (ferrous) with protective coatings or aluminum (nonferrous).

- ✓ **Uses Permitted** - EMT shall be permitted to be used in the ff:
 1. Exposed and concealed works.
 2. Areas subject to severe corrosive influences protected by corrosion protection.
 3. Areas of wet locations where materials shall be made of corrosion-resistant materials.
- ✓ **Uses Not Permitted** - EMT shall not be used in the following:
 1. Where subject to physical damage.
 2. Protected from corrosion solely by enamel.
 3. In cinder concrete or cinder fills subject to permanent moisture.
 4. In any hazardous (classified) location except as permitted.
 5. Support of luminaires (fixtures) or other equipment.
 6. Where practicable, dissimilar metals in contact anywhere in the system.
- ✓ **Size**
 - **Minimum** - EMT less than raceway size 15 mm shall not be used.
 - **Maximum** - EMT larger than raceway size 100 mm shall not be used.
- ✓ **Reaming** - All cut ends shall be rimmed or otherwise finished to remove rough edges.
- ✓ **Threading** - EMT shall not be threaded.
- ✓ **Securing and Supporting**
 - **Securely Fastened and Supported** - 900 mm within of each outlet, junction, and device box cabinet, conduit body, and supported and fastened at intervals within 3000 mm.
- ✓ **Marking** - EMT shall be durably marked at least every 3000 mm.

FLEXIBLE METALLIC TUBING: TYPE FMT

Flexible Metallic Tubing - A raceway that is circular in cross section, flexible, metallic, and liquidtight without a nonmetallic jacket

- ✓ **Size**
 - **Minimum** - FMT less than raceway size 15 mm shall not be used
 - **Maximum** - FMT larger than raceway size 20 mm shall not be used

Uses Permitted	Uses Not Permitted
In dry locations	In hoistways
Where concealed	In storage battery rooms
In accessible locations	In hazardous (classified) locations unless permitted
For system voltages of 1000 volts maximum	Burial purposes, embedded in concrete or aggregate
	Where subject to physical damage
	In lengths over 1800 mm

ELECTRICAL NONMETALLIC TUBING: TYPE ENT

Electrical Nonmetallic Tubing - A nonmetallic pliable corrugated raceway of circular cross section with integral or associated couplings, connectors, and fittings for the installation of electric conductors. ENT is composed of a material that is resistant to moisture and chemical atmospheres and is flame retardant.

A pliable raceway can be bent by hand with a reasonable force but without other assistance

- ✓ **Size**
 - **Minimum** - ENT less than raceway size 15 mm shall not be used.
 - **Maximum** - ENT larger than raceway size 50 mm shall not be used.
- ✓ **Trimmings** - All cut ends shall be trimmed inside and outside to remove rough edges.
- ✓ **Securing and Supporting**
 - **Securely Fastened and Supported** - 900 mm within of each outlet, junction, and device box cabinet, conduit body, and supported and fastened at intervals within 900 mm.
- ✓ **Construction** - ENT shall be made of materials that do not exceed ignitability, flammability, smoke generation, and toxicity characteristics of rigid (non-plasticized) polyvinyl chloride.
- ✓ **Marking** - ENT shall be durably marked at least every 3000 mm including type, size, and quantity of conductors included.

Uses Permitted	Uses Not Permitted
Subject to severe corrosive influences	In hazardous (classified) locations unless permitted
Concealed, dry, and damp locations (not prohibited)	Support of luminaires (fixtures) or other equipment
Above suspended ceilings (w/ 15 min. finish rating)	Ambient temp. in excess of 50°C (unless listed)
Encased in poured concrete, embedded in concrete slab	Direct earth burial
Wet locations indoors	Exposed locations (except permitted)
Raceway, 15 mm through 25 mm prewired assembly	Theaters and similar locations
	Where subject to physical damage, direct rays of sun

AUXILIARY GUTTERS

Metallic Auxiliary Gutters - Sheet metal enclosures with hinged or removable covers for housing and protecting electric wires, cable, and busbars in which conductors are laid in place after the wireway.

Nonmetallic Auxiliary Gutters - Flame retardant, nonmetallic enclosures with removable covers for housing and protecting electric wires, cable, and busbars in which conductors are laid in place after the wireway.

- ✓ **Uses Permitted** - Shall be permitted to supplement wiring spaces at meter centers, distribution centers, switchboards, and similar points of wiring systems and may enclose conductors or busbars.
 1. **Sheet Metal Auxiliary Gutters**
 - Indoor and Outdoor Use
 - Wet Locations
 2. **Nonmetallic Auxiliary Gutters**
 - ✓ Indoor and Outdoor Use
- ✓ **Uses Not Permitted** - Auxiliary Gutters shall not be used in the following:
 1. To enclose switches, overcurrent devices, appliances, or other similar equipment.
 2. To extend a greater distance than 9000 mm beyond the equipment that it supplements.
- ✓ **Number of Conductors** - The total area of conductors shall not exceed 20% of the gutter.
- ✓ **Securing and Supporting**
 - **Sheet Metal Auxiliary Gutters** - Shall be supported at intervals within 1500mm.
 - **Nonmetallic Auxiliary Gutters** - Shall be supported at intervals within 900 mm.

BUSWAYS

Busways - A grounded metal enclosure containing factory-mounted, bare or insulated conductors, which are usually a copper or aluminum bars, rods, or tubes.

- ✓ **Uses Permitted** - Busways shall be permitted be installed in the following locations:
 1. **Exposed** - Shall be located in the open where visible.
 2. **Concealed** - Shall be permitted behind access panels, provided busways are totally enclosed, of non-ventilating type construction.
 3. **Through Walls and Floors** - Shall be installed in walls of unbroken lengths and floor penetrations.
- ✓ **Uses Not Permitted**
 1. Where subject to physical damage or corrosive vapors.
 2. Installed in hoistways.
 3. In hazardous (classified) locations unless permitted.
 4. Installed outdoors or in wet or damp locations.
 5. Working platforms of lighting and trolley busway less than 2400 mm above the floor.
- ✓ **Support** - Busways shall be securely supported at intervals not exceeding 1500 mm.
- ✓ **Dead Ends** - A dead end of a busway shall be closed.
- ✓ **Grounding** - Busway shall be grounded
- ✓ **Requirements for Over 600 Volts, Nominal**
 - Barriers and Seals - Vapor Seals and Fire Barriers
 - Drain Facilities
 - Adjacent and Supporting Structures
 - Ventilated Bus Enclosures
 - Terminations, Connections, Switches
- ✓ **Neutral** - Neutral bus, where required shall be sized to carry all neutral load current, including harmonic currents, and shall have adequate momentary and short-current rating.
- ✓ **Marking** - Each busway run shall be provided with a permanent nameplate with the ff:
 - Rated voltage
 - Rated continuous current
 - Rated frequency
 - Rated impulse withstand voltage
 - Rated 60-Hz withstand voltage (dry)
 - Rated momentary current
 - Manufacturer's name or trademark

CABLEBUS

Cablebus - An assembly of insulated conductors with fittings and conductor terminations in a completely enclosed ventilated protective metal housing.

- ✓ **Types of Conductors** - Conductors shall have insulation rating of 75°C or higher.
- ✓ **Size and Number of Conductors** - Conductors shall not be smaller than 50 mm².
- ✓ **Conductor Supports** - Individual conductors in a cablebus shall be supported at intervals not greater than 900 mm for horizontal runs and 450 mm for vertical runs.
- ✓ **Support** - Cable bus shall be securely supported at intervals not exceeding 3600 mm.
- ✓ **Marking** - Each section shall be marked with manufacturer's name or trade designation and the maximum diameter, number, voltage rating, and ampacity of the conductors to be installed.

CELLULAR FLOOR RACEWAYS (CONCRETE AND METAL)

Cellular Metal Floor Raceway - The hollow spaces of cellular metal floors, together with suitable fittings, that may be approved as enclosures for electric conductors.

Cell - A single, enclosed tubular space in a floor made of precast cellular concrete slabs or metal, the direction of the cell being parallel to the direction of the floor member.

Header - Transverse metal raceways for conductors, providing access to predetermined cells of a precast cellular concrete floor.

- ✓ **Uses Not Permitted**
 1. Where subject to corrosive vapors.
 2. In commercial garages, other than for supplying ceiling outlets.
- ✓ **Size and Number of Conductors** - Conductors shall not be larger than 50 mm².
- ✓ **Maximum Number of Conductors** - The combined cross sectional area of all conductors or cables shall not exceed 40 percent of the cross-sectional area of the cell or header.

WIREWAYS

Metal Wireways - Sheet metal troughs with hinged or removable covers for housing and protecting electric wires and cable and in which conductors are laid in place after the wireway.

Nonmetallic Wireways - Flame retardant, nonmetallic troughs with removable covers for housing and protecting electric wires and cables in which conductors are laid in place after the wireway.

CONCEALED KNOB-AND-TUBE-WIRING

Concealed Knob-and-Tube Wiring - A wiring method using knobs, tubes, and flexible nonmetallic tubing for the protection and support of single insulated conductors.

- ✓ **Uses Not Permitted**
 1. For extensions of existing installations.
- ✓ **Uses Not Permitted**
 1. Commercial garages
 2. Theaters, motion picture studios, and similar locations.
 3. Hollow spaces of walls, ceilings, and attics
- ✓ **Clearances** - 75 mm between conductors and 25 mm between the conductor and surface.
- ✓ **Supporting** - Supported at intervals within 1400 mm and within 150 mm of each side of tap.

OTHER APPROVED WIRING METHODS BY P.E.C.

STRUT-TYPE CHANNEL RACEWAY

-A metallic raceway mounted to the surface of or suspended from a structure, with associated accessories for the installation of electrical conductors and cables.

SURFACE RACEWAYS (METAL AND NON METAL)

- A raceway that is intended to be mounted to the surface of a structure, with associated couplings, connectors, boxes, and fittings for the installation of electrical conductors.

MESSENGER SUPPORTED WIRING

- An exposed wiring support system using a messenger wire to support insulated conductors.

CHAPTER 4 - EQUIPMENT FOR GENERAL USE

FLEXIBLE CORD/CABLE

Table 4.0.1.5 Adjustment Factors for More Than Three Current-Carrying Conductors in a Flexible Cord or Cable	
Number of Conductors	Percent of Value in Tables 4.0.1.5(a) and 4.0.1.5(b)
4 – 6	80
7 – 9	70
10 – 20	50
21 – 30	45
31 – 40	40
41 and above	35

FIXTURE WIRES

Types of Fixture Wires with Trade Name and Operating Temperatures					
Trade Name	Type Letter	Operating Temp.	Trade Name	Type Letter	Operating Temp.
Heat-resistant rubber-covered fixture wire-flexible stranding	FFH-2	75°C	Heat-resistant rubber covered - solid/7 strand	RFH-2	90°C
ECTFE - solid/7-strand	HF	150°C	Heat-resistant cross-linked synthetic polymer-solid/7-strand	RFHH-2* RFHH-3*	200°C
ECTFE - flexible strand	HFF	150°C	Silicon insulated-solid/7-strand	SF-1 SF-2	200°C
Tape insulated fixture wire - solid/7-strand	KF-1 KF-2	200°C	Silicon insulated- flexible stranding	SF-1 SF-2	150°C
Tape insulated fixture wire - flexible stranding	KF-1 KF-2	200°C	Thermoplastic wire-solid/7-strand	TF*	60°C
Perfluoro-alkoxy - solid/7-strand	PAF	250°C	Thermoplastic wire-flexible stranding	TFF*	60°C
Perfluoro-alkoxy - flexible stranding	PAFF	150°C	Heat-resistant thermoplastic covered-solid/7-strand	TFN*	90°C
Flourinated ethylene propylene-solid/7-strand	PF PGF	200°C	Heat-resistant thermoplastic covered-flexible stranded	TFFN*	90°C
Flourinated ethylene propylene-flexible strand	PFF PGFF	150°C	Cross-linked polyolefin insulated-solid/7-strand	XF*	150°C
Extruded polytetrafluoroethylene - solid/7-strand	PTF	250°C	Cross-linked polyolefin insulated-flexible strand	XFF*	150°C
Extruded polytetrafluoroethylene - flexible stranding	PTFF	150°C	Modified ETFE (solid/7-strand)	ZF	150°C
Heat-resistant rubber covered - solid/7-strand	RFH-1	75°C	Flexible stranding	ZFF	150°C
			High temp modified ETFE-solid/7-strand	ZHF	200°C

Allowable Ampacity for Fixture (luminaire) Wires	
Size mm² (mm dia.)	Allowable Ampacity
0.75 (1.0)	6
1.25 (1.2)	8
2.0 (1.6)	17
3.5 (2.6)	23
5.5 (2.6)	28

Minimum Size

- The fixture (luminaire) wires shall not be smaller than 0.75 mm² (1.2 mm dia.)

Marking

- The thermoplastic insulated fixture (luminaire) wire shall be durably marked on the surface at intervals not exceeding 600 mm. All other fixture shall be marked by means of printed tag attached to the coil and reel.

SWITCHES

Location

- The grip of the operating handle of the switch or circuit breaker is not more than 1980 mm above the floor or working platform.

Mounting of Snap Switches

1. **Surface-Type** - Shall be mounted on insulating materials that separates the conductors at least 13 mm from the surface wired over.
2. **Box Mounted** - Flush-type snap switches shall be mounted in boxes installed so that extension plaster ears are seated against the surface.

Knife Switches

1. **Isolating Switches** - 1200 amperes at 250 volts or less, and at over 600 amperes at 251V to 600V.
2. **To Interrupt Currents** - 1200 amperes at 250 volts or less, and over 600 amperes at 251V to 600V.

Rating and Use of Snap Switches

1. **Alternating-Current General Use**
 - Resistive and inductive loads, including electric-discharge lamps.
 - Tungsten-filament lamp loads not exceeding 115 volts.
 - Motor loads not exceeding 80 percent of ampere rating.
2. **Alternating-Current/Direct-Current General Use**
 - Resistive loads
 - Inductive loads not exceeding 50% of ampere rating.
 - Tungsten-filament lamp loads not exceeding 115 volts.
3. **CO/ALR Snap Switches** - rated 20 ampere or less directly connected to aluminum conductors.
4. **Dimmer Switches** - shall be used only to control permanently installed incandescent luminaires.

RECEPTACLES, CORD CONNECTORS, AND ATTACHMENT PLUGS (CAPS)

Rating

- Receptacles and cord connectors shall be rated not less than 15A, 125V, or 15A, 250V, and shall be of a type not suitable for use as lampholders.

Receptacles for Aluminum Conductors

- Shall be rated 20A or less and designed for direct connection of aluminum conductors and shall be marked with CO/ALR.

Receptacle Mounting

1. **Boxes That Are Set Back** - The mounting yoke or strap is held rigidly at the finished surface.
2. **Boxes That Are Flush** - The mounting yoke or strap is held rigidly at the finished surface.
3. **Receptacles Mounted on Covers** - Held rigidly by one or more screws, or be a device assembly.
4. **Position of Receptacle Faces** - Flushed and project a minimum of 0.38 mm from metal faceplates.
5. **Receptacles in Countertops** - Shall not be installed in a face-up position.
6. **Exposed Terminals** - Enclosed so that live wiring terminals are not exposed to contact.

Receptacle Faceplates (Cover Plates)

1. **Thickness of Metal Faceplates** - Ferrous Metal (0.75 mm thick); Nonferrous Metal (1.00 mm thick)
2. **Grounding** - Metal faceplates shall be grounded.
3. **Faceplates of Insulating Material** - Shall be noncombustible not less than 0.25 mm thick; permitted to be less than 0.25 mm thick if formed or reinforced to provide adequate mechanical strength.

SWITCHBOARDS AND PANELBOARDS

Supports and Arrangement of Busbars and Conductors

1. Overheating and inductive effects shall be avoided.
2. Shall be installed with a main bonding if used as service equipment.
3. Phase arrangement on 3-phase buses shall be A, B, C.

Switchboards

- a) **Clearance** - The clearance from the ceiling shall not be less than 900 mm to the top of the switchboard.
- b) **Location of Switchboards** - Switchboards shall be located in permanently dry locations and then where competent supervision and accessible to only licensed electrical practitioner.

Panelboards

- a) **Classification of Panelboards**
 1. **Lighting and Appliance Branch-Circuit Panelboard**
 - Shall have overcurrent protection of 30 ampere or less.
 - Shall have more than 10% of its overcurrent devices protect lighting and appliance branch circuits.
 2. **Power Panelboard**
 - Shall have 10% or fewer overcurrent devices protect lighting and appliance branch circuits.
- b) **Number of Overcurrent Devices in One Panelboards**
 - Shall have not more than 42 overcurrent devices of lighting and appliance branch-circuit panelboard.
 - 2-pole circuit breakers (21 overcurrent devices in the panel)
 - 3-pole circuit breakers (14 overcurrent devices in the panel)
- c) **Overcurrent Protection**
 - **Lighting and Appliance Branch-Circuit Panelboard Individually Protected** - Shall be individually protected on the supply side by not more than 2 main circuit breakers or 2 sets of fuses.
 - **Power Panelboard Protection** - Shall be protected of an overcurrent device which is not greater than the size of the protection for the panelboard.
 - **Snap Switches Rated at 30 Ampere or Less** - Shall have an overcurrent protection of 200A or less.
 - **Supplied Through a Transformer** - Shall have an overcurrent protection on the secondary side of the transformer.
 - **Delta Breakers** - Shall not be installed in the panelboards.
 - **Back-Fed Devices** - Shall be secured in place by an additional fastener.
- d) **Panel** - Made of moisture resistant, noncombustible material.
- e) **Busbars** - Insulated or bare busbars shall be rigidly mounted.
- f) **Protection of Instrument Circuits** - Instruments, pilot lights, potential transformers, or other switchboard devices with potential coils shall be protected at 15 Ampere or less.

INDUSTRIAL CONTROL PANEL

Industry Control Panel - An assembly of a systematic and standard arrangement of two or more components such as motor controllers, overload relays, fused disconnect switches, and circuit breakers and related control devices such as pushbutton stations, selector switches, timers, switches, control relays, and the like with associated wiring, terminal blocks, pilot lights, and similar components. The industrial control panel does not include the controlled equipment.

Minimum Size and Ampacity

- Industrial control panels shall be rated 125% of the full-load current.

LUMINAIRES (LIGHTING FIXTURES), LAMPHOLDERS, AND LAMPS

Luminaire (Fixtures) in Specific Locations

- a) **Wet and Damp Locations** - Shall be made so that water cannot enter. It shall be marked "Suitable for Wet Locations" or "Suitable for Damp Locations".
- b) **Corrosive Locations** - Shall be a type suitable for such locations.
- c) **In Ducts or Hoods** - The temperature limits in the area shall not be exceeded. Material shall be excluded from vapors, grease, oil, or cooking vapors, and shall be corrosion resistant.
- d) **Bathtub and Shower Areas** - No lighting fixtures (cord-suspended luminaires), light tracks, pendants, or ceiling suspended fans within 900 mm horizontally and 2400 mm vertically from the top of the bathtub rim or shower stall threshold.

Luminaires (Fixtures) Near or Over Combustible Materials

- Luminaires near combustible materials shall not be subject to temperature in excess of 90°C. And, shall be located at least 2400 mm above the floor or so guarded that lamps can't be damaged.

Luminaires (Fixtures) in Clothes Closets

- a) **Luminaire (Fixture) Types Permitted**
 1. Surface-mounted or Recessed Incandescent Luminaire
 2. Surface-mounted or Recessed Fluorescent Luminaire
- b) **Luminaire (Fixture) Types Not Permitted**
 1. Incandescent Luminaires (Fixtures) with open or partially enclosed lamps.
 2. Pendant Luminaires (Fixtures)
 3. Lampholders
- c) **Clearances Permitted for Different Luminaire Fixture (From the Nearest Storage Space)**
 1. Surface-mounted incandescent luminaire - 300 mm
 2. Surface-mounted fluorescent luminaire - 150
 3. Recessed incandescent luminaire - 150 mm
 4. Recessed fluorescent luminaire - 150 mm

Wiring of Luminaires

- Wirings of luminaires shall have the same polarity for screw shells of lamp holders, and circuit terminals.

Pendant Conductors for Incandescent Filament Lamps

- a) **Size** - Pendant conductors shall comply with the ff:
 - Mogul-base, medium-base screw-hell lampholders - not smaller than 2.0 mm² (1.6 mm dia.)
 - Intermediate or Candelabra base lampholder - not smaller than 0.75 mm² (1.0 mm. dia.)
- b) **Twisted or Cabled** - longer than 900 mm shall be twisted together.

Branch Circuit Conductors and Ballasts

- Branch circuit conductors shall be within 75 mm from the ballasts with temperature rating not lower than 90°C.

Lighting Track

- A manufactured assembly designed to support and energize luminaires (lighting fixtures) that are capable of being readily repositioned on the track. Its length can be altered by the addition or subtraction of sections of track.

APPLIANCES

Provisions for appliances (In General):

- Shall not be less than 125% of the marked rating for motor-operated appliances.
- Shall not be less than 100% of the marked rating rated at continuous loading.

Overcurrent Protection

- a) **Household-Type Appliances with Surface Heating Elements** - With a maximum demand of more than 60A, it must have 2 or more circuits for power supply with protection rated at not over 50A.
- b) **Infrared Lamp Commercial and Industrial Heating Appliances** - Shall have an overcurrent protection not exceeding 50A.
- c) **Single Non-motor-Operated Appliance**
 - Shall not exceed the nameplate rating marked on the appliance.
 - Shall not exceed 20A rating if the current is 13.3A or less.

Fixed Electric Space Heating

- a) **Marking of Heating Cables**
 - 120 volt, nominal — yellow
 - 208 volt, nominal — blue
 - 240 volt, nominal — red
 - 277 volt, nominal — brown
 - 480 volt, nominal — orange
- b) **Clearances of Wiring in Ceilings** - Wiring shall not be less than 50 mm above the heated ceiling with an ambient temperature of 50°C.

MOTORS, MOTOR CIRCUITS, AND CONTROLLERS

Adjustable Speed Drive - A combination of the power converter, motor, and motor mounted auxiliary devices (encoders, tachometers, thermal switches and detectors, air blowers, heaters, and vibration sensors).

Motor Control Circuit - The circuit of a control apparatus or system that carries the electric signals directing the performance of the controller but does not carry the main power current.

System Isolation Equipment - A redundantly monitored, remotely operated contactor-isolating system, packaged to provide the disconnection/isolation function, capable of verifiable operation from multiple remote locations by means of lockout switches, each having the capability of being padlocked in the “off” (open) position.

Part Winding Transformer

- a) Started by energizing first its primary (armature) winding, and subsequently the remainder of this winding in one or more steps.
- b) 1/2 of its primary winding can be energized initially, and the other half follows in one or more steps.
- c) A hermetic refrigerant compressor shall not be considered a std. part-winding start induction motor.

Ampacity and Motor Rating Determination

- a) **General Motor Applications** - Motors considered are low speeds when less than 1200 RPM.
 1. High Speed - Low Torque, Lower Full-Load Current
 2. Low Speed - High Torque, Higher Full-Load Current
- b) **Torque Motors** - The rated current shall be the locked-rotor current

Marking on Motors and Multi-motor Equipment

1. Manufacturer’s name
2. Rated volts and full-load current
3. Rated frequency and number of phases if an ac motor
4. Rated full-load speed
5. Rated temperature rise or the insulation system class and rated ambient temperature
6. Time rating. The time rating shall be 5, 15, 30, or 60 minutes, or continuous
7. Rated horsepower if 1/8 hp or more
8. Code letter or locked-rotor amperes if an alternating-current
9. Design letter for design B, C, or D motors
10. Secondary volts and full-load current if a wound-rotor induction motor
11. Field current and voltage for dc excited synchronous motors
12. Winding - straight shunt, stabilized shunt, compound, or series, if a dc motor. Fractional horsepower dc motors 180 mm or less in diameter shall not be required to be marked.
13. Thermal Protection Marking “Thermally Protected” or “T.P.”
14. “Impedance Protected” “Z.P.” for impedance protected motors
15. Motors equipped with electrically powered condensation prevention heaters shall be marked with the rated heater voltage, number of phases, and the rated power in watts

Terminals

- a) **Markings** - The terminals shall be marked or colored if necessary.
- b) **Conductors** - The conductors shall be connected with copper unless otherwise identified.
- c) **Torque Requirements** - 0.8 N-m torque for screw-type pressure terminals with 2.0 mm² (1.6 mm dia.)

Single Motor (Selection of Branch-Circuit Conductors)

- a) **General** - The ampacity of branch circuit shall not be less than 125% of the motor’s full-load current.
- b) **Multispeed Motor** - The highest full-load current rating shall be the one shown on the motor nameplate.
- c) **Wye-Start, Delta-Run Motor** - Shall be sized at 58% of the motor full load current.
- d) **Part-Winding Motor** - Shall be sized 50% of the motor full-load current.
- e) **Other than Continuous Duty** - Conductors for a motor used in short-time, intermittent, periodic, or varying duty application, shall have ampacity not less than the motor nameplate current rating.
- f) **Separate Terminal Enclosure** - Conductors between a stationary motor rated 1 hp or less shall be permitted to be smaller than 2.0 mm² (1.6 mm dia.) but not smaller than 0.75 mm² (1.0 mm dia.).

Rating for Continuous-Duty Motors

- a) **More Than 1 Horsepower**
 1. **Separate Overload Device**
 - 125% - Marked with a service factor 1.15 or greater
 - 125% - Motors with a marked temperature rise 40°C
 - 115% - All other motors
 2. **Thermal Protector**
 - 170% - Full-load current of 9A or less
 - 156% - Full-load current of 9.1 to 20 amperes
 - 140% - Full-load current greater than 20 amperes
 3. **Integral with Motor** - Shall protect the motor against damage due to failure to start.
 4. **Larger than 1500HP** - Shall have an OCD having embedded temperature detectors.
- b) **One Horsepower or Less, Automatically Started**
 1. Separate Overload Device
 2. Thermal Protector
 3. Integral with Motor
 4. Impedance-Protected

c) **Selection of Overload Relay**

- 140% - Marked with a service factor of 1.15 or greater
- 140% - Motors with a marked temperature rise 40°C
- 130% - All other motors

Automatic Restarting

- An overload device that can restart a motor automatically after overload tripping shall not be installed unless approved if automatic restarting may result in injury to persons.

Table 4.30.1.7(b) Locked-Rotor Indicating Code Letters

Code Letter	Kilovolt-Amperes per Horsepower with Locked Rotor
A	0-3.14
B	3.15-3.54
C	3.55-3.99
D	4.0-4.49
E	4.5-4.99
F	5.0-5.59
G	5.6-6.29
H	6.3-7.09
J	7.1-7.99
K	8.0-8.99
L	9.0-9.99
M	10.0-11.19
N	11.2-12.49
P	12.5-13.99
R	14.0-15.99
S	16.0-17.99
T	18.0-19.99
U	20.0-22.39
V	22.4 and up

Table 4.30.4.2 Maximum Rating or Setting of Motor Branch-Circuit Short-Circuit and Ground-Fault Protective Devices

Type of Motor	Percentage of Full-Load Current			
	Nontime Delay Fuse ¹	Dual Element (Time-Delay) Fuse ¹	Instantaneous Trip Breaker	Inverse Time Breaker ²
Single-phase motors	300	175	800	250
AC polyphase motors other than wound-rotor				
Squirrel cage — other than Design B energy-efficient	300	175	800	250
Design B energy-efficient	300	175	1 100	250
Synchronous ³	300	175	800	250
Wound rotor	150	150	800	150
Direct current (constant voltage)	150	150	250	150

Table 4.30.7.11 Motor Controller Enclosure Selection										
For Outdoor Use										
Provides a Degree of Protection Against the Following Environmental Conditions	Enclosure Type Number¹									
	3	3R	3S	3X	3RX	3SX	4	4X	6	6P
Incidental contact with the enclosed equipment	X	X	X	X	X	X	X	X	X	X
Rain, snow, and sleet	X	X	X	X	X	X	X	X	X	X
Sleet ²	—	—	X	—	—	X	—	—	—	—
Windblown dust	X	—	X	X	—	X	X	X	X	X
Hosedown	—	—	—	—	—	—	X	X	X	X
Corrosive agents	—	—	—	X	X	X	—	X	—	X
Temporary submersion	—	—	—	—	—	—	—	—	X	X
Prolonged submersion	—	—	—	—	—	—	—	—	—	X

For Indoor Use										
Provides a Degree of Protection Against the Following Environmental Conditions	Enclosure Type Number¹									
	1	2	4	4X	5	6	6P	12	12K	13
Incidental contact with the enclosed equipment	X	X	X	X	X	X	X	X	X	X
Falling dirt	X	X	X	X	X	X	X	X	X	X
Falling liquids and light splashing	—	X	X	X	X	X	X	X	X	X
Circulating dust, lint, fibers, and flyings	—	—	X	X	—	X	X	X	X	X
Settling airborne dust, lint, fibers, and flyings	—	—	X	X	X	X	X	X	X	X
Hosedown and splashing water	—	—	X	X	—	X	X	—	—	—
Oil and coolant seepage	—	—	—	—	—	—	—	X	X	X
Oil or coolant spraying and splashing	—	—	—	—	—	—	—	—	—	X
Corrosive agents	—	—	—	X	—	—	X	—	—	—
Temporary submersion	—	—	—	—	—	X	X	—	—	—
Prolonged submersion	—	—	—	—	—	—	X	—	—	—

Disconnecting Means

- a) **Location**
 - Controller - Individual disconnecting means shall be provided for each controller.
 - Motor - Disconnecting means shall be located in sight of the motor location.
- b) **Operation** - The disconnecting means shall open all ungrounded supply conductors and shall be designed so that no pole can be operated independently.
- c) **Readily Accessible** - Shall have at least one of the disconnecting means be readily accessible.
- d) **Types** - The types of disconnecting means shall be specified by the ff:
 1. Motor Circuit Switch
 2. Molded Case Circuit Breaker
 3. Molded Case Switch
 4. Instantaneous Trip Circuit Breaker
 5. Self-Protected Combination Controller
 6. Manual Motor Controller - shall be marked “Suitable as Motor Disconnect”
 7. System Isolation Equipment
 8. Stationary Motor of 1/8HP or Less - the branch circuit overcurrent device
 9. Autotransformer-Type Controlled Motor - for motors 2HP to 100HP
- e) **Ampere Rating and Interrupting Capacity** - Shall not be less than 115% of the full-load current rating of the motor, 600 volts, nominal.
- f) **Switch or Circuit Breaker as Both Controller and Disconnecting Means**
 - Air-Break Switch - Shall be operable directly by hand on the lever or handle.
 - Inverse Time Circuit Breaker - Shall be operable by hand; manually and power operable.
 - Oil Switch - The rating shall not exceed 600 volts or 100 amperes.

Table 4.30.14.3 Full-Load Current, Two-Phase Alternating-Current Motors (4-Wire)

The following values of full-load current are for motors running at speeds usual for belted motors and motors with normal torque characteristics. Current in the common conductor of a 2-phase, 3-wire system will be 1.41 times the value given. The voltages listed are rated motor voltages. The currents listed shall be permitted for system voltage ranges of 110 to 120, 220 to 240, 440 to 480, and 550 to 600 volts.

Horsepower	Induction-Type Squirrel Cage and Wound Rotor (Amperes)				
	115 Volts	230 Volts	460 Volts	575 Volts	2 300 Volts
½	4.0	2.0	1.0	.08	—
¾	4.8	2.4	1.2	1.0	—
1	6.4	3.2	1.6	1.3	—
1½	9.0	4.5	2.3	1.8	—
2	11.8	5.9	3.0	2.4	—
3	—	8.3	4.2	3.3	—
5	—	13.2	6.6	5.3	—
7½	—	19	9.0	8.0	—
10	—	24	12	10	—
15	—	36	18	14	—
20	—	47	23	19	—
25	—	59	29	24	—
30	—	69	35	28	—
40	—	90	45	36	—
50	—	113	56	45	—
60	—	133	67	53	14
75	—	166	83	66	18
100	—	218	109	87	23
125	—	270	135	108	28
150	—	312	156	125	32
200	—	416	208	167	43

Table 4.30.14.2 Full-Load Currents in Amperes, Single-Phase Alternating-Current Motors

The following values of full-load currents are for motors running at usual speeds and motors with normal torque characteristics. The voltages listed are rated motor voltages. The currents listed shall be permitted for system voltage ranges of 110 to 120 and 220 to 240 volts.

Horsepower	115 Volts	200 Volts	208 Volts	230 Volts
¼	4.4	2.5	2.4	2.2
	5.8	3.3	3.2	2.9
	7.2	4.1	4.0	3.6
½	9.8	5.6	5.4	4.9
¾	13.8	7.9	7.6	6.9
1	16	9.2	8.8	8.0
1½	20	11.5	11.0	10
2	24	13.8	13.2	12
3	34	19.6	18.7	17
5	56	32.2	30.8	28
7½	80	46.0	44.0	40
10	100	57.5	55.0	50

Table 4.30.14.5(a) Conversion Table of Single-Phase Locked-Rotor Currents for Selection of Disconnecting Means and Controllers as Determined from Horsepower and Voltage Rating
For use only with 4.30.9.10, 4.40.2.2, 4.40.5.1, and 4.55.1.8(c).

Rated Horsepower	Maximum Locked-Rotor Current in Amperes, Single Phase		
	115 Volts	208 Volts	230 Volts
½	58.8	32.5	29.4
¾	82.8	45.8	41.4
1	96	53	48
1 ½	120	66	60
2	144	80	72
3	204	113	102
5	336	186	168
7 ½	480	265	240
10	600	332	300

Table 4.30.14.4 Full-Load Current, Three-Phase Alternating-Current Motors

The following values of full-load currents are typical for motors running at speeds usual for belted motors and motors with normal torque characteristics. The voltages listed are rated motor voltages. The currents listed shall be permitted for system voltage ranges of 110 to 120, 220 to 240, 440 to 480, and 550 to 600 volts.

Horsepower	Induction-Type Squirrel Cage and Wound Rotor (Amperes)						Synchronous-Type Unity Power Factor* (Amperes)				
	115 Volts	200 Volts	208 Volts	230 Volts	460 Volts	575 Volts	2300 Volts	230 Volts	460 Volts	575 Volts	2300 Volts
½	4.4	2.5	2.4	2.2	1.1	0.9	—	—	—	—	—
¾	6.4	3.7	3.5	3.2	1.6	1.3	—	—	—	—	—
1	8.4	4.8	4.6	4.2	2.1	1.7	—	—	—	—	—
1½	12.0	6.9	6.6	6.0	3.0	2.4	—	—	—	—	—
2	13.6	7.8	7.5	6.8	3.4	2.7	—	—	—	—	—
3	—	11.0	10.6	9.6	4.8	3.9	—	—	—	—	—
5	—	17.5	16.7	15.2	7.6	6.1	—	—	—	—	—
7½	—	25.3	24.2	22	11	9	—	—	—	—	—
10	—	32.2	30.8	28	14	11	—	—	—	—	—
15	—	48.3	46.2	42	21	17	—	—	—	—	—
20	—	62.1	59.4	54	27	22	—	—	—	—	—
25	—	78.2	74.8	68	34	27	—	53	26	21	—
30	—	92	88	80	40	32	—	63	32	26	—
40	—	120	114	104	52	41	—	83	41	33	—
50	—	150	143	130	65	52	—	104	52	42	—
60	—	177	169	154	77	62	16	123	61	49	12
75	—	221	211	192	96	77	20	155	78	62	15
100	—	285	273	248	124	99	26	202	101	81	20
125	—	359	343	312	156	125	31	253	126	101	25
150	—	414	396	360	180	144	37	302	151	121	30
200	—	552	528	480	240	192	49	400	201	161	40
250	—	—	—	—	302	242	60	—	—	—	—
300	—	—	—	—	361	289	72	—	—	—	—
350	—	—	—	—	414	336	83	—	—	—	—
400	—	—	—	—	477	382	95	—	—	—	—
450	—	—	—	—	515	412	103	—	—	—	—
500	—	—	—	—	590	472	118	—	—	—	—

*For 90 and 80 percent power factor, the figures shall be multiplied by 1.1 and 1.25, respectively.

Table 4.30.14.5(b) Conversion Table of Polyphase Design B, C, and D Maximum Locked-Rotor Currents for Selection of Disconnecting Means and Controllers as Determined from Horsepower and Voltage Rating and Design Letter

For use only with 4.30.9.10, 4.40.2.2, 4.40.5.1 and 4.55.1.8(c).

Rated Horsepower	Maximum Motor Locked-Rotor Current in Amperes, Two- and Three-Phase, Design B, C, and D*					
	115 Volts	200 Volts	208 Volts	230 Volts	460 Volts	575 Volts
	B, C, D	B, C, D	B, C, D	B, C, D	B, C, D	B, C, D
½	40	23	22.1	20	10	8
¾	50	28.8	27.6	25	12.5	10
1	60	34.5	33	30	15	12
1½	80	46	44	40	20	16
2	100	57.5	55	50	25	20
3	—	73.6	71	64	32	25.6
5	—	105.8	102	92	46	36.8
7½	—	146	140	127	63.5	50.8
10	—	186.3	179	162	81	64.8
15	—	267	257	232	116	93
20	—	334	321	290	145	116
25	—	420	404	365	183	146
30	—	500	481	435	218	174
40	—	667	641	580	290	232
50	—	834	802	725	363	290
60	—	1001	962	870	435	348
75	—	1248	1200	1085	543	434
100	—	1668	1603	1450	725	580
125	—	2087	2007	1815	908	726
150	—	2496	2400	2170	1085	868
200	—	3335	3207	2900	1450	1160
250	—	—	—	—	1825	1460
300	—	—	—	—	2200	1760
350	—	—	—	—	2550	2040
400	—	—	—	—	2900	2320
450	—	—	—	—	3250	2600
500	—	—	—	—	3625	2900

A motors are not limited to a maximum starting current or locked rotor current.

AIR-CONDITIONING AND REFRIGERATING EQUIPMENT

Hermetic Refrigerant Motor-Compressor - Consist of a compressor and motor, both of which are enclosed in the same housing, with no external shaft or shaft seals the motor operating in the refrigerant.

Leakage Current Detection and Interruption (LCDI) Protection - A device provided in a power supply cord or cord set that senses leakage current flowing between or from the cord conductors and interrupts the circuit at a predetermined level of leakage current.

Branch Circuit Conductors

- Single Motor-Compressor - Compressors shall have a rating of 125% ampacity of the full-load current.
- Wye-Start, Delta-Run Connected Motor-Compressor - Shall have a rating of 72% ampacity of the full-load rated current.

GENERATORS

Marking

- Each generator shall be provided with a nameplate with the following information:

- Manufacturer’s Name
- Rated Frequency
- Power Factor
- Nominal Volts and Amperes
- Rated Speed (RPM)
- Insulation System Class
- KW or KVA Rating
- Time Rating
- Rated Ambient Temperature
- Temperature Rise
- Number of Phase if AC
- Subtransient and Transient Impedances

Overcurrent Protection (Required)

- a) **Constant-Voltage Generators** - Shall be protected from overloads by inherent design, CB, fuses, etc.
- b) **Two-Wire Generator** - Shall be permitted to have an OCP in one conductor only.
- c) **65 Volts or Less** - Shall be protected to not deliver more than 150% of the full-load current.
- d) **Balancer Sets** - Two wire, dc generators used in conjunction with balancer sets.
- e) **Three-Wire, DC Generators** - Whether compound or shunt wound, overcurrent protection shall be installed, one for each armature lead.

Ampacity of Conductors

- Shall be protected not less than 115% of the nameplate current rating of the generator

TRANSFORMERS AND TRANSFORMER VAULTS (INCLUDING SECONDARY TIES)

Table 4.50.1.3(b) Maximum Rating or Setting of Overcurrent Protection for Transformers					
600 Volts and Less (as a Percentage of Transformer-Rated Current)					
Protection Method	Primary Protection			Secondary Protection (See Note 2.)	
	Currents of 9 Amperes or More	Currents Less Than 9 Amperes	Currents Less Than 2 Amperes	Currents of 9 Amperes or More	Currents Less Than 9 Amperes
Primary only protection	125%	167%	300%	Not required	Not required
Primary and secondary protection	250%	250%	250%	125%	167%

Autotransformers 600 Volts, Nominal, or Less

- Shall be protected by an OCD not less than 125% of the rated full-load current.

Secondary Ties

- A circuit operating at 600 volts, nominal, or less between phases.

Marking

- Each transformer shall be provided with a nameplate with the following information:

- Manufacturer’s Name
- Rated Frequency
- Primary and Secondary Voltage
- Rated Kilovolt-Ampere (KVA)
- Impedance for 25KVA size and larger
- Required Clearances for Transformers with Ventilating Opening
- Amount and Kind of Insulating Liquid
- Temperature Class for the Insulation System

Specific Provisions Applicable to Different Types of Transformers

- a) **Dry-Type Transformers Installed Indoors**
 1. Not Over 112 ½ KVA - Shall have a separation of at least 300 mm from combustible material unless separated from the combustible materials by a fire-resistant, heat-insulated barrier.
 2. Over 112 ½ KVA - Shall be installed in a transformer room of fire resistant construction.
 3. Over 35,000 Volts - Transformers shall be installed in a vault room.
- b) **Dry-Type Transformers Installed Outdoors** - Transformers shall have a weatherproof enclosure, not located within 300 mm of combustible materials unless it has a Class 155 insulation systems or higher.
- c) **Less-Flammable Liquid-Insulated Transformers** - Insulated and has fire point not less than 300°C.
 1. **Indoor Installations** - Permitted as long as the following conditions are met:
 - In Type I or Type II buildings
 - The transformer is rated 35kV or less
 - No combustible materials are stored
 - A liquid confinement area is provided
 - With an automatic fire extinguishing system and liquid confinement area
 2. **Outdoor Installations**- less flammable, liquid-filled transformers installed adjacent to, or on the roof
- d) **Nonflammable Fluid-Insulated Transformers** - Shall be installed in a vault and furnished with a liquid confinement area and a pressure-relief vent. It shall be also furnished with a means for absorbing gases generated by arcing inside the tank.
- e) **Askarel-Insulated Transformers Installed Indoors** - Furnished with a pressure-relief vent.
- f) **Oil-Insulated Transformers Installed Indoors** - Shall be installed in a vault.
- g) **Oil-Insulated Transformers Installed Outdoors** - Shall be safeguarded from combustible material, combustible buildings, and parts of buildings, fire escapes, and door and window openings.

Transformer Vaults

- a) **Location** - Can be ventilated to the outside air without using flues or ducts.
- b) **Walls, Roofs, and Floors** - Materials for the walls and roofs shall have adequate mechanical strength with fire resistance of 3 hours. The floors of the vault made in concrete shall not be less than 100 mm thick and has an adequate structural strength with fire resistance of 3 hours.
- c) **Doorways**
 1. **Type of Door** - Tight-fitting door with fire rating of 3 hours.
 2. **Sills** - Has a height of not less than 100 mm.
 3. **Locks** - Rooms shall be kept locked and only licensed electrical practitioner is allowed.
- d) **Ventilation Openings**
 1. **Locations** - As far as possible from doors, windows, fire escapes, and combustible materials.
 2. **Size** - If ventilated by natural circulation, the combined area of openings (1900 mm² per KVA) and not less than 0.1 m² for any capacity under 50KVA.
 3. **Coverings** - Covered with durable gratings, screens, or louvers.

4. **Dampers** - With automatic closing fire dampers with fire rating of not less than 1½ hours.
5. **Ducts** - Shall be constructed of fire-resistant material.
- e) **Drainage** - Shall be provided for 100KVA transformer capacities that will carry off any accumulation of oil or water in the vault.
- f) **Water Pipes and Accessories** - No pipe or duct system shall enter or pass through the vault. Piping for vault fire protection, or for transformer cooling is allowed
- g) **Storage in Vaults** - The materials should not be installed in the transformer vaults

CAPACITORS

Enclosing and Guarding

- Capacitors containing more than 11L (3 gal) of flammable liquid shall be enclosed in vaults or outdoor fenced enclosures.

600 Volts, Nominal, Under

- a) **Time of Discharge** - The residual voltage shall be reduced to 50 volts, nominal, or less within 1 minute after the capacitor is disconnected from the source of supply.
- b) **Conductors** - The ampacity of the conductors shall not be less than 135% of the rated current.
- c) **Disconnecting Means** - The disconnecting means shall open all ungrounded conductors simultaneously and be rated 135% of the rated current.
- d) **Marking**
 - Manufacturer's Name
 - Rated Frequency
 - Rated Kilovar or Amperes
 - Number of Phases
 - Volume of Liquid (if filled w/ liquid)
 - Rated Voltage

Over 600 Volts, Nominal

- a) **Switching** - Group-operated switches shall be used for capacitor switching and be the ff:
 1. Carrying continuously not less than 135% of the rated capacitor current.
 2. Interrupting the maximum continuous load current of each load.
 3. Withstanding the maximum inrush current.
 4. Carrying currents due to faults on capacitors side of switch.
- b) **Additional Requirements for Series Capacitors**
 1. Mechanically sequenced isolating and bypass switches
 2. Interlocks
 3. Switching procedure prominently displayed at the switching locations
- c) **Identification** - Each capacitor shall have a nameplate with the following information:
 - Manufacturer's Name
 - Rated Frequency
 - Rated Kilovar or Amperes
 - Number of Phases
 - Volume of Liquid (if filled w/ liquid)
 - Rated Voltage
- d) **Time of Discharge** - The residual voltage shall be reduced to 50 volts, nominal, or less within 5 minute after the capacitor is disconnected from the source of supply.

RESISTORS AND REACTORS

Space Separation

- 600 Volts or Less - A thermal barrier within 300 mm of any combustible material.
- Over 600 Volts - Shall have a clearance of 305 mm (12 in.) from combustible material.

Conductor Insulation

- Conductor insulation shall be suitable for operating in temperature of not less than 90°C.

STORAGE BATTERIES

Nominal Battery Voltage

- Lead-Acid Type - 2V/cell for the lead-acid type
- Alkali Type - 1.2V/cell

Sealed Cell or Battery

- A sealed cell or battery is one that has no provision for the addition of water or electrolyte or for external measurement of electrolyte specific gravity.

Storage Battery

- A battery comprised of one or more rechargeable cells of the lead-acid, nickel-cadmium, or other rechargeable electrochemical types.

Table 4.90.2.4 Minimum Clearance of Live Parts*						
Nominal Voltage Rating (kV)	Impulse Withstand, B.I.L (kV)		Minimum Clearance of Live Parts			
			Phase-to-Phase		Phase-to-Ground	
	Indoors	Outdoors	Indoors (mm)	Outdoors (mm)	Indoors (mm)	Outdoors (mm)
2.4-4.16	60	95	115	180	80	155
7.2	75	95	140	180	105	155
13.8	95	110	195	305	130	180
14.4	110	110	230	305	170	180
23	125	150	270	385	190	255
34.5	150	150	320	385	245	255
	200	200	460	460	335	335
46	—	20	—	460	—	335
	—	250	—	535	—	435
69	—	250	—	535	—	435
	—	350	—	790	—	635
115	—	550	—	1350	—	1070
138	—	550	—	1350	—	1070
	—	650	—	1605	—	1270
161	—	650	—	1605	—	1270
	—	750	—	1830	—	1475
230	—	750	—	1830	—	1475
	—	900	—	2265	—	1805
	—	1050	—	2670	—	2110

*The values given are the minimum clearance for rigid parts and bare conductors under favorable service conditions. They shall be increased for conductor movement or under unfavorable service conditions or wherever space limitations permit. The selection of the associated impulse withstand voltage for a particular system voltage is determined by the characteristics of the surge protective equipment.

CHAPTER 5 - SPECIAL OCCUPANCIES

Associated Nonincendive Field Wiring Apparatus - Apparatus in which the circuits are not necessarily nonincendive themselves but that affects the energy in nonincendive field wiring circuits and is relied upon to maintain nonincendive energy levels.

Combustible Gas Detection System - A protection technique utilizing stationary gas detectors

Dust-Ignitionproof - Equipment enclosed in a manner that excludes dusts and does not permit arcs, sparks, or heat otherwise generated or liberated inside of the enclosure to cause ignition of exterior accumulations or atmospheric suspensions of a specified dust on or in the vicinity of the enclosure.

Dusttight - Enclosures constructed so that dust will not enter under specified test conditions.

Explosionproof Apparatus - Apparatus enclosed in a case that is capable of withstanding an explosion of a specified gas or vapor that may occur within it and of preventing the ignition of a specified gas or vapor surrounding the enclosure by sparks, flashes, or explosion of the gas or vapor within, and that operates at such an external temperature that a surrounding flammable atmosphere will not be ignited thereby.

Hermetically Sealed Equipment - sealed against the entrance of an external atmosphere where the seal is made by fusion, for example, soldering, brazing, welding, or the fusion of glass to metal.

Oil Immersion - Electrical equipment immersed in a protective liquid in such a way that an explosive atmosphere that may be above the liquid or outside the enclosure cannot be ignited.

Purged and Pressurized

- ✓ **Purging** - supplying an enclosure with a protective gas at a sufficient flow and positive pressure to reduce the concentration of any flammable gas/vapor initially present to an acceptable level.
- ✓ **Pressurization** - supplying an enclosure with a protective gas with or without continuous flow at sufficient pressure to prevent flammable gas/vapor, a combustible dust, or an ignitable fiber to enter.

Nonincendive Circuit - A circuit, other than field wiring, in which any arc or thermal effect produced under intended operating conditions of the equipment, is not capable, under specified test conditions, of igniting the flammable gas-air, vapor-air, or dust-air mixture

Nonincendive Equipment - Equipment having electrical/electronic circuitry that is incapable, under normal operating conditions, of causing ignition of a specified flammable gas-air, vapor-air, or dust-air mixture due to arcing or thermal means.

Reference Standards of Hazardous Locations

- ✓ National Fire Protection Association (NFPA)
- ✓ American Petroleum Institute (API)
- ✓ Instrumentation Systems and Automation Society (ISA)

Maximum Temperature °C	Temperature Class (T Code)
450	T1
300	T2
280	T2A
260	T2B
230	T2C
215	T2D
200	T3
180	T3A
165	T3B
160	T3C
135	T4
120	T4A
100	T5
85	T6

HAZARDOUS LOCATIONS

Classifications

- Locations have been classified depending on the properties of the flammable vapors, liquid, or gasses, or combustible dusts or fibers that may be present.

CLASS I LOCATIONS - Flammable gases or vapor are present in air which is sufficient to produce explosive or ignitable mixtures.

➤ **CLASS I, DIVISION 1**

- a) Ignitable concentrations of flammable gases or vapors can exist.
- b) Existence of gas due to frequent repair or maintenance operation or because of leakage.
- c) Release of such gasses due to breakdown, failure or faulty operation of equipment.

➤ **CLASS I, DIVISION 2**

- a) Volatile flammable liquids or flammable gases are handled, processed, but in which liquids and gases are confined and can escape only in case of accidental rupture or breakdown, or such abnormal operation.
- b) Mechanical ventilations prevent ignitable concentrations of gases or vapors and failure or abnormal operation might become hazardous.
- c) Gases or vapors might occasionally be communicated unless such communication is prevented by adequate positive-pressure ventilation from a source of clean air.

CLASS II LOCATIONS - Locations that has presence of combustible dust.

➤ **CLASS II, DIVISION 1**

- a) Combustible dust is in the air under normal operating conditions.
- b) Where mechanical failure of abnormal operation of machinery or equipment might cause such explosive or ignitable mixtures to be produced.
- c) Group E combustible dusts may be present in quantities sufficient to be hazardous.

➤ **CLASS II, DIVISION 2**

- a) Presence of combustible due to abnormal operations
- b) Dust accumulations are present in normal operation but are insufficient to be hazardous but infrequent malfunctioning of handling/processing equipment it would be hazardous

CLASS III LOCATIONS - Locations that has the presence of ignitable fibers or flyings.

- **CLASS III, DIVISION 1** - Ignitable fibers are handled, manufacture or used.
- **CLASS III, DIVISION 2** - Ignitable fibers are stored, handled and manufactured.

MATERIAL GROUPS

MESG - Maximum Experimental Safe Gap

MIC - Minimum Igniting Current Ratio

Classifications:

CLASS I GROUP CLASSIFICATIONS

- ✓ **Group A-** Acetylene
- ✓ **Group B-** Flammable gas, flammable liquid-produced vapor, or combustible liquid-produced vapor mixed with air that may burn or explode, MESG value is less than or equal 0.45 mm, MIC ratio is less than or equal to 0.40 mm.
- ✓ **Group C-** Flammable gas, flammable liquid-produced vapor, or combustible liquid-produced vapor mixed with air that may burn or explode, MESG value is greater than 0.45 mm and less than or equal to 0.75 mm, MIC ratio than 0.40 and less than or equal to 0.80.
- ✓ **Group D-** Flammable gas, flammable liquid-produced vapor, or combustible liquid-produced vapor mixed with air that may burn or explode, MESG value > 0.75 mm, MIC ratio > 0.80.

CLASS II GROUP CLASSIFICATIONS

- ✓ **Group E-** Atmospheres containing combustible metal dusts, including aluminum, magnesium, and their commercial alloys, or other combustible dusts whose particle size, abrasiveness, and conductivity present similar hazards in the use of electrical equipment
- ✓ **Group F-** Atmospheres containing combustible carbonaceous dusts that have more than 8 percent total entrapped volatiles. Carbonaceous dust ex. Coal, carbon black, charcoal, and coke dusts.
- ✓ **Group G-** Atmospheres containing combustible dusts not included in Group E or F, including flour, grain, wood, plastic, and chemicals.

CLASS I, ZONE 0, 1, AND 2 LOCATIONS

Types of Protection:

- ✓ **Encapsulation “m.”** - Encloses the parts w/c could ignite the atmosphere by sparking or heating.
- ✓ **Flameproof “d.”** - Enclosure can withstand an internal explosion of flammable mixture that has penetrated into the interior, without suffering damage and w/o causing ignition in joints or openings.
- ✓ **Increased Safety “e.”** - Applied to electrical equipment that does not produce arcs in normal service and under specified abnormal conditions, increased security is given against the possibility of excessive temperatures and of the occurrence of arcs and sparks.
- ✓ **Intrinsic Safety “i.”** - Any spark or thermal effect is incapable of causing ignition of a mixture of flammable or combustible material in air under prescribed test conditions.
- ✓ **Oil Immersion “o.”** - Electrical equipment is immersed in a protective liquid in such a way that an explosive atmosphere that may be above the liquid or outside the enclosure cannot be ignited.
- ✓ **Powder Filling “q.”** - Electrical parts capable of igniting an explosive atmosphere are fixed in position and completely surrounded by filling material (glass or quartz powder) to prevent the ignition of an external explosive atmosphere.
- ✓ **Type of Protection “n.”** - Electrical equipment, in normal operation, is not capable of igniting a surrounding explosive gas atmosphere and a fault capable of causing ignition is not likely to occur.

Classification of Locations:

- **Class I, Zone 0** - Ignitable concentrations of flammable gases or vapors are present continuously or for long periods of time
- **Class I, Zone 1**
 - a) Ignitable concentrations of flammable gas/vapors may exist under normal conditions
 - b) Ignitable concentrations of flammable gas/vapors may exist because of repair/ maintenance
 - c) Equipment breakdown or faulty operation could result in the release of ignitable concentrations of flammable gas/vapors
- **Class I, Zone 2**
 - a) Ignitable concentrations of flammable gas/vapors are not likely to occur under normal conditions; but if they do, will exist only for short period
 - b) Volatile flammable liquids or flammable gases are handled, processed, but in which liquids and gases are confined and can escape only in case of accidental rupture or breakdown, or such abnormal operation.

Zone Equipment Marking

- Equipments shall be marked with all the following in the order shown:

- a) Class
- b) Zone
- c) Symbol “AEx”
- d) Protection technique(s)
- e) Applicable gas classification group(s)
- f) Temperature classification

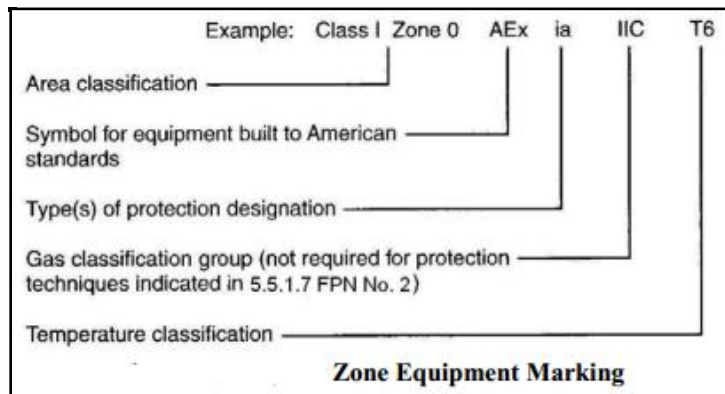

Table 5.5.1.9(c)(2)d Types of Protection Designation

Designation	Technique	Zone*
d	Flameproof enclosure	1
e	Increased safety	1
ia	Intrinsic safety	0
ib	Intrinsic safety	1
[ia]	Associated apparatus	Unclassified
[ib]	Associated apparatus	Unclassified
m	Encapsulation	1
nA	Nonsparking equipment	2
nC	Sparking equipment in which the contacts are suitably protected other than by restricted breathing enclosure	2
nR	Restricted breathing enclosure	2
o	Oil immersion	1
p	Purged and pressurized	1 or 2
q	Powder filled	1

ZONE 20, 21, AND 22 LOCATIONS

Zone 20 Hazardous (Classified) Locations

- An area where combustible dust or ignitable fibers and flyings are present continuously or for long periods of time in quantities sufficient to be hazardous.

Zone 21 Hazardous (Classified) Locations

- An area where combustible dust or ignitable fibers and flyings are likely to exist occasionally under normal operation in quantities sufficient to be hazardous.

Zone 22 Hazardous (Classified) Locations

- An area where combustible dust or ignitable fibers and flyings are not likely to occur under normal operation in quantities sufficient to be hazardous.

MOTOR FUEL DISPENSING FACILITIES

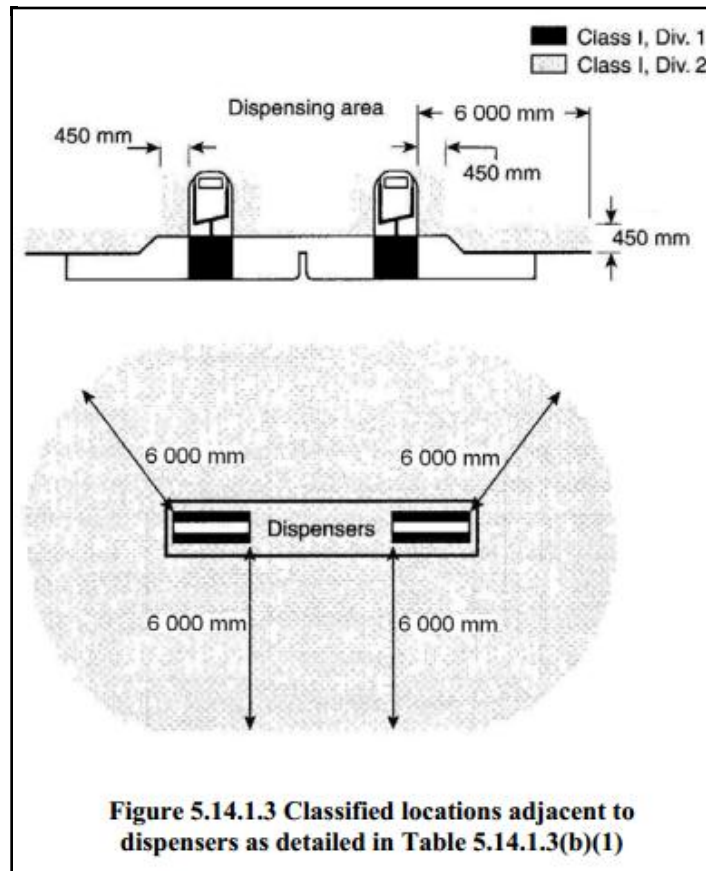

HEALTH CARE FACILITIES

Alternate Power Source - One or more generator sets, or batter systems where permitted, intended to provide power during the interruption of the normal electrical services or the public utility electrical service intended to provide power during interruption of service normally provided by the generating facilities on the premises.

Ambulatory Health Care Facility - A building or part thereof used to provide services or treatment to four or more patients at the same time.

Critical Branch - A subsystem of the emergency system consisting of feeders and branch circuits supplying energy to task illumination, special power circuits, and selected receptacles serving areas and functions related to patient care, and which are connected to alternate power sources by one or more transfer switches during interruption of the normal power source.

Electrical Life-Support Equipment - Electrically powered equipment whose continuous operation is necessary to maintain a patient's life.

Emergency System - A system of circuits and equipment intended to supply alternate power to a limited number of prescribed functions vital to the protection of life and safety.

Health Care Facilities - Buildings or portions of buildings in which medical, dental, psychiatric, nursing, obstetrical, or surgical care are provided. Health care facilities include, but are not limited to, hospitals, nursing homes, limited care facilities, clinics, medical and dental offices, and ambulatory care centers, whether permanent or movable.

Hospital - A building or part thereof used for the medical, psychiatric, obstetrical, or surgical care, on a 24-hour basis, of four or more inpatients. Hospital shall include general hospitals, mental hospitals, tuberculosis hospitals, children's hospitals, and any such facilities providing inpatient care.

Isolation Transformer - A transformer of the multiple-winding type, with the primary and secondary windings physically separated, which inductively couples its secondary winding to the grounded feeder systems that energize its primary winding.

Patient Vicinity - In an area in which patients are normally cared for, the patient vicinity is the space with surfaces likely to be contacted by the patient or an attendant who can touch the patient. Typically in a patient room, this encloses a space within the room not less than 1800 mm beyond the perimeter of the bed in its nominal location, and extending vertically not less than 2300 mm above the floor.

General Care Areas

- a) **Patient Bed Location** - Shall be supplied by at least 2 branch circuits, one for the emergency system and the other for the normal system.
- b) **Patient Bed Location Receptacles** - Shall be provided with a minimum of 4 receptacles either a single or duplex types or a combination of both. All receptacles, whether four or more, shall be listed "hospital grade" and so identified.
- c) **Pediatric Locations** - Receptacles located within the rooms, bathrooms, playrooms, activity rooms, and patient care areas of pediatric wards shall be listed tamper resistant.

Critical Care Areas

- a) **Patient Bed Location Branch Circuits** - Shall be supplied by at least 2 branch circuits, one for the emergency system and the other for the normal system. At least 1 branch circuit from emergency system shall supply an outlet(s) only at that bed location.
- b) **Patient Bed Location Receptacles** - Shall be provided with a minimum of 6 receptacles and listed "hospital grade". Each receptacle shall be grounded by copper equipment grounding conductor.
- c) **Patient Vicinity Grounding and Bonding (Optional)** - An equipment bonding jumper not smaller than 5.5 mm² (2.6 mm dia.) shall be used to connect the grounding terminal of receptacles.
- d) **Special-Purpose Receptacle Grounding** - Equipment grounding conductor for special-purpose receptacles, such as operation of mobile X-ray equipment, shall be extended to the reference grounding points of the branch circuits.
- e) **Ground-Fault Circuit-Interrupter Protection for Personnel** - Ground-fault circuit-interrupter protection for personnel shall not be required for receptacles installed in those critical care areas where the toilet and basin are installed within the patient room.
- f) **Transfer Switches** - Each branch of the emergency system and each equipment system shall have one or more transfer switches. One transfer switch shall be permitted to serve one or more branches or systems in a facility with a maximum demand on the essential electrical system of 150 KVA.

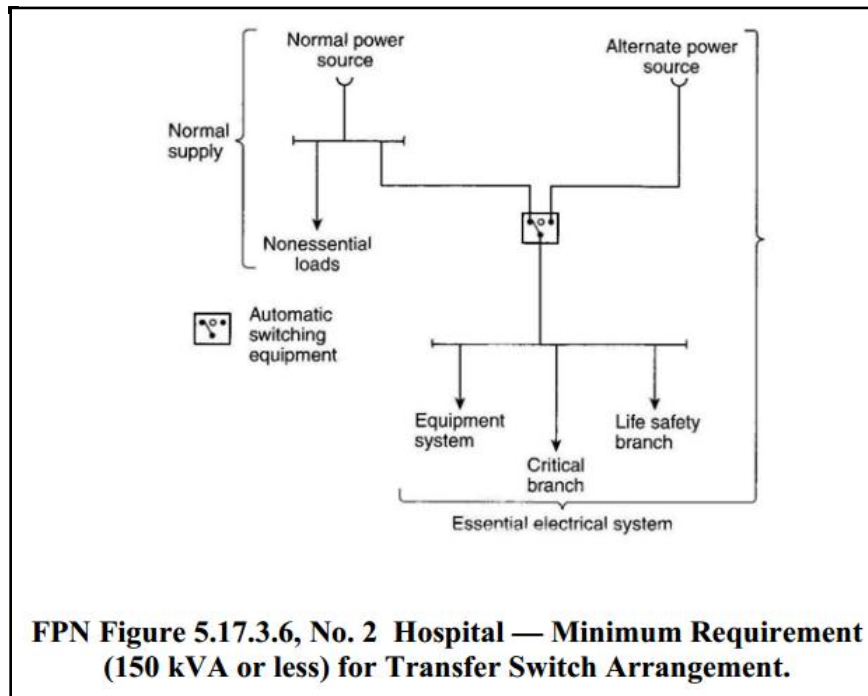
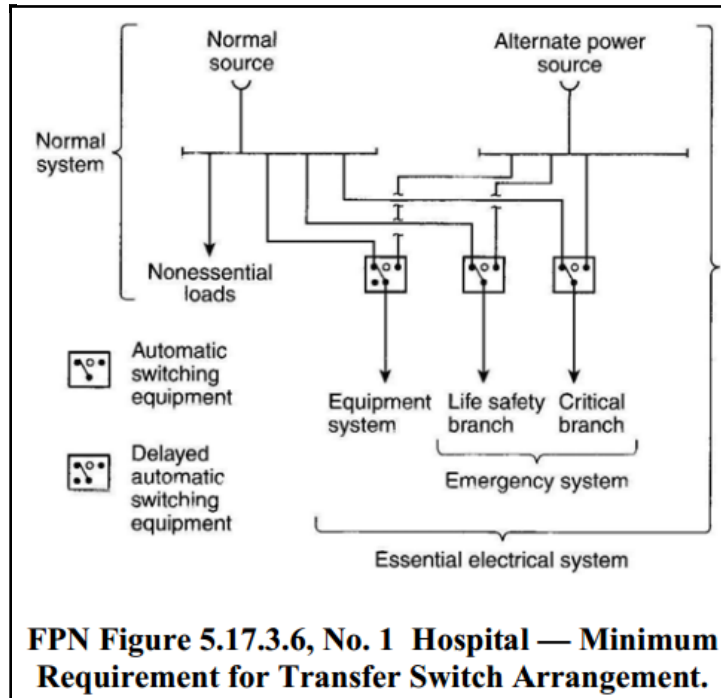

Task Illumination and Selected Receptacles for Critical Branch

- The critical branch of the emergency system shall supply power for task illumination, fixed equipment, selected receptacles, and special power circuits serving the following areas and functions related to patient care:

1. Critical care areas that utilize anesthetizing gases
2. The isolated power systems in special environments
3. Patient care areas - task illumination and selected receptacles in the following:
 - a. Infant nurseries
 - b. Medication preparation areas
 - c. Pharmacy dispensing areas
 - d. Selected acute nursing areas
 - e. Psychiatric bed areas (omit receptacles)
 - f. Ward treatment rooms
 - g. Nurses' stations (unless adequately lighted by corridor luminaires)
4. Additional specialized patient care task illumination and receptacles, where needed
5. Nurse call systems
6. Blood, bone, and tissue banks
7. Telephone equipment rooms and closets
8. Task illumination, selected receptacles, and selected power circuits for the following:
 - a. General care beds (at least one duplex receptacle per patient bedroom)
 - b. Angiographic labs
 - c. Cardiac catheterization labs
 - d. Coronary care units
 - e. Hemodialysis rooms or areas
 - f. Emergency room treatment areas (selected)
 - g. Human physiology labs
 - h. Intensive care units
 - i. Postoperative recovery rooms (selected)
9. Additional task illumination, receptacles, and selected power circuits needed

ASSEMBLY OCCUPANCIES

Multiple Occupancies - Occupancy of any room or space for assembly of 100 persons or more.

Theatrical Areas-These are any such building structure or portion thereof, contains a projection booth or stage platform or area for the presentation of theatrical or musical productions.

- Assembly occupancies shall include, but not be limited to, the following:

Armories	Dance halls	Places of awaiting transportation
Assembly Halls	Dining and drinking facilities	Places of religious worship
Auditoriums	Exhibition halls	Pool rooms
Bowling lanes	Gymnasiums	Restaurants
Club rooms	Mortuary chapels	Skating rinks
Conference rooms	Multipurpose rooms	
Courtrooms	Museums	

Temporary Wiring

- Flexible cables and cords approved for hard or extra-hard usage shall be permitted to be laid on floors where protected from contact by the general public.

Wiring in General

- The fixed wiring methods shall be metal raceways, flexible metal raceways, nonmetallic raceways encased in not less than 50 mm of concrete, Type MI, MC, or AC cable with an insulated EGC.

THEATERS, AUDIENCE AREAS OF MOTION PICTURE AND TELEVISION STUDIOS, PERFORMANCE AREAS, AND SIMILAR LOCATIONS

Border Light - A permanently installed overhead strip light.

Breakout Assembly - An adapter used to connect a multipole connector containing two or more branch circuits to multiple individual branch-circuit connectors.

Bundled - Cables/conductors that are physically tied, wrapped, taped or periodically bound together.

Connector Strip - A metal wireway containing pendant or flush receptacles.

Drop Box A box containing pendant or flush-mounted receptacles attached to a multiconductor cable via strain relief or a multipole connector.

Footlight - A border light installed on or in the stage.

Grouped - Cables or conductors adjacent to one another but not in continuous contact with each other.

Performance Area - The stage and audience seating area associated with a temporary stage structure, whether indoors or outdoors, constructed of scaffolding, truss, platforms, or similar devices, that is used for the presentation of theatrical or musical productions or for public presentations.

Portable Equipment - fed with portable cords/cables intended to be moved from a place to another.

Portable Power Distribution Unit - A power distribution box with receptacles and overcurrent devices.

Proscenium - The wall and arch that separates the stage from the auditorium (house).

Stand Lamp (Work Light) - A portable stand that contains a general-purpose luminaire or lampholder with guard for the purpose of providing general illumination on the stage or in the auditorium.

Strip Light - A luminaire (lighting fixture) with multiple lamps arranged in a row.

Two-Fer - An adapter cable containing one male plug and two female cord connectors used to connect two loads to one branch circuit.

Wiring Methods

- The fixed wiring method shall be metal raceways, nonmetallic raceways encased in at least 50 mm of concrete Type MI cable, MC cable, or AC cable containing an insulated equipment grounding conductor.

Dressing Rooms

- a) **Pendant Lampholders** - Pendant lampholders shall not be installed in dressing rooms.
- b) **Lamp Guards** - All exposed incandescent lamps in dressing rooms, where less than 2 400 mm from the floor, shall be equipped with open-end guards riveted to the outlet box cover or otherwise sealed or locked in place.
- c) **Switches Required** - All lights and any receptacles adjacent to the mirror(s) and above the dressing table counter(s) installed in dressing rooms shall be controlled by wall switches installed in the dressing room(s). Each switch controlling receptacles adjacent to the mirror(s) and above the dressing table counter(s) shall be provided with a pilot light located outside the dressing room, adjacent to the door to indicate when the receptacles are energized.

CARNIVALS, CIRCUSES, FAIRS, AND SIMILAR EVENTS

Overhead Conductor Clearances

- Amusement rides and amusement attractions shall be maintained not less than 4500 mm in any direction from overhead conductors which are rated 600V, nominal, less or higher

Disconnecting Means

- Each ride and concession shall be provided with fused disconnect switch or circuit breaker located within sight and within 1800 mm of the operator's station.

Portable Distribution or Termination Box

- Where installed outdoors, the box shall be of weatherproof construction and mounted so that the bottom of the enclosure is not less than 150 mm above the ground.

MOTION PICTURE AND TELEVISION STUDIOS AND SIMILAR LOCATIONS

Alternating-Current Power Distribution Box (Alternating-Current Plugging Box, Scatter Box) - Contains 1/more grounding-type polarized receptacles that may contain overcurrent protection devices.

Bull Switch - An externally operated wall-mounted safety switch that may or may not contain overcurrent protection and is designed for the connection of portable cables and cords.

Location Board (Deuce Board) - Portable equipment containing a lighting contactor or contactors and overcurrent protection designed for remote control of stage lighting.

Plugging Box - A dc device consisting of one or more 2-pole, 2-wire, nonpolarized, nongrounding-type receptacles intended to be used on dc circuits only.

Single-Pole Separable Connector- A device that is installed at the ends of portable, flexible, single conductor cable that is used to establish connection or disconnection between two cables or one cable and a single-pole, panel-mounted separable connector.

Spider (Cable Splicing Block) - A device that contains busbars that are insulated from each other for the purpose of splicing or distributing power to portable cables and cords that are terminated with single-pole busbar connectors.

Permanent Wiring

- Shall be Type MC Cable, Type AC cable containing equipment grounding.

MOTION PICTURE PROJECTION ROOMS

Professional Projector - A type of projector using 35- or 70-mm film that has a minimum width of 35 mm and has on each edge 212 perforations per meter, or a type using carbon arc, xenon, or other light source equipment that develops hazardous gases, dust, or radiation.

Work Space

- Each motion picture projector, floodlight, spotlight, or similar equipment shall have clear working space not less than 800 mm wide on each side and at the rear thereof.

Conductor Size

- Conductors supplying outlets for arc and xenon projectors of the professional type shall not be smaller than 8.0 mm² and shall be of sufficient size for the projector employed.

MOBILE HOMES, MANUFACTURED HOMES, AND MOBILE PARKS

Manufactured Home - A structure, transportable in one or more sections, that is 2400 mm or more in width or 12 m or more in length in the traveling mode or, when erected on site, is 30 m² or more; which is built on a chassis and designed to be used as a dwelling, with or without a permanent foundation, when connected to the required utilities, including the plumbing, heating, air conditioning, and electrical systems contained therein. Calculations used to determine the number of square meters in a structure will be based on the structure's exterior dimensions, measured at the largest horizontal projections when erected on site. These dimensions include all expandable rooms, cabinets, and other projections containing interior space but do not include inside bay windows.

Mobile Home - A factory-assembled structure or structures transportable in one or more sections that is built on a permanent chassis and designed to be used as a dwelling without a permanent foundation where connected to the required utilities and that includes the plumbing, heating, air-conditioning, and electric systems contained therein.

Mobile Homes Not Intended as Dwelling Unit

- Shall not be required to meet the provisions for the number or capacity of circuits required.

Power Supply

- a) **Feeder** - Not more than one listed 50A mobile home power supply cord with an integrally molded or securely attached plug cap or a permanently installed feeder.
- b) **Attachment Plug Cap** - Shall be a 2-pole, 3-wire, grounding type, rated 50 amperes, 250 volts or 3-pole, 4-wire, grounding type, rated 50 amperes, 125/250 volts and intended for use with the 50-ampere, 250-volt and 125/250-volt receptacle.
- c) **Overall Length of a Power-Supply Cord** - Shall not be less than 6400 mm and shall not exceed 11 m. The length of the cord from the face of the attachment plug cap to the point where the cord enters the mobile home shall not be less than 6000 m.

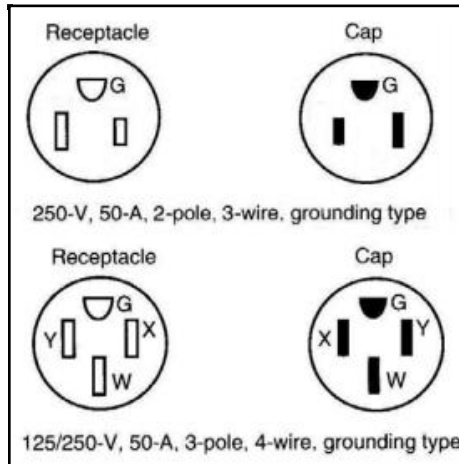

Marking

- The power-supply cord shall bear the following marking: “FOR USE WITH MOBILE HOMES - 40 AMPERES” or “FOR USE WITH MOBILE HOMES - 50 AMPERES”

Point of Entrance

- The point of entrance shall be in the exterior wall, floor, or roof.

Protected

- Shall be permitted to be installed within the mobile home walls, provided a continuous raceway having a maximum size of 30 mm is installed from the branch-circuit panelboard to the underside of the mobile home floor.

Number of Mobile Homes	Demand Factor (Percent)
1	100
2	55
3	44
4	39
5	33
6	29
7-9	28
10-12	27
13-15	26
16-21	25
22-40	24
41-60	23
61 and over	22

RECREATIONAL VEHICLES AND RECREATIONAL VEHICLE PARKS

Recreational Vehicle - A vehicular-type unit primarily designed as temporary living quarters for recreational, camping, or travel use, which either has its own motive power or is mounted on or drawn by another vehicle. The basic entities are travel trailer, camping trailer, truck camper, and motor home.

Recreational Vehicle Park - A plot of land upon which two or more recreational vehicle sites are located, established, or maintained for occupancy by recreational vehicles of the general public as temporary living quarters for recreation or vacation purposes.

Means for Connecting to Power Supply

- a) **Cord** - The cord exposed usable length, measured to the point of entry on the vehicle exterior, shall be a minimum of 7600 mm where the point of entrance is at the side of the vehicle or shall be a minimum 9000 mm where the point of entrance is at the rear of the vehicle.
- b) **Attachment Plugs**

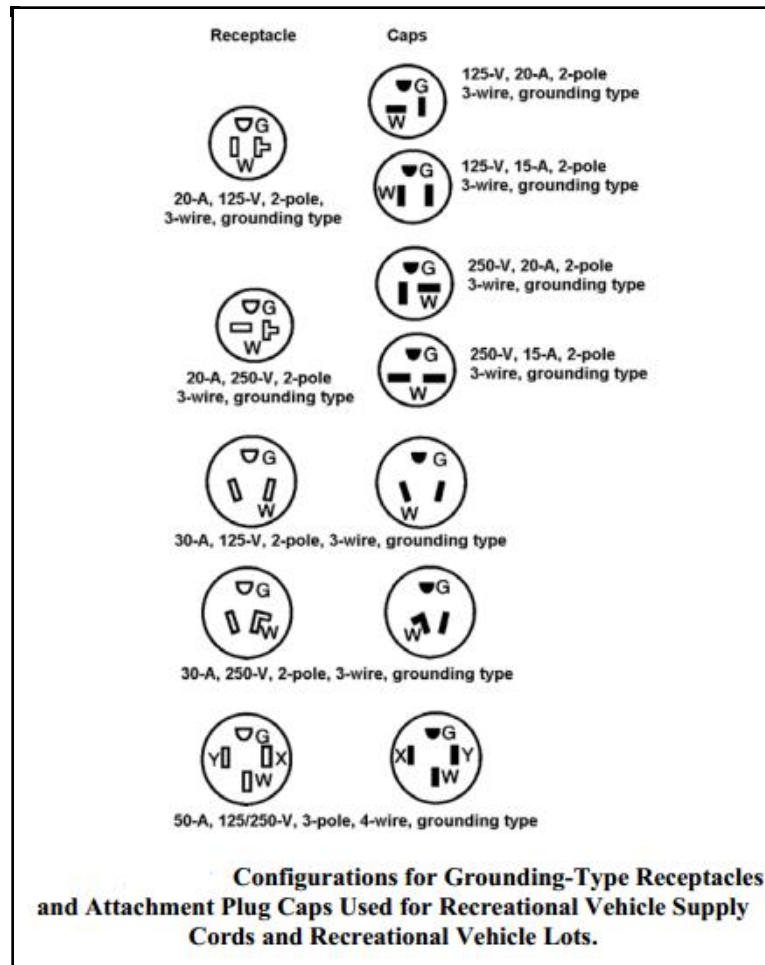

- c) **Label at Electrical Entrance** - Shall have permanently affixed to the exterior skin, at or near the point of entrance of the power-supply cord(s), a label 75 mm × 45 mm minimum size, made of etched, metal-stamped, or embossed brass, stainless steel, or anodized or alum/clad >0.50 mm thick.
THIS CONNECTION IS FOR 115/230VOLT AC,
3-POLE, 4-WIRE, 60 HZ, _____ AMPERE SUPPLY
- d) **Location** - The assembly shall be located within 4500 mm of the rear, on the left (road) side or at the rear, left of the longitudinal center of the vehicle, within 460 mm of the outside wall.

Number of Recreational Vehicles Sites	Demand Factor (percent)
1	100
2	90
3	80
4	75
5	65
6	60
7-9	55
10-12	50
13-15	48
16-18	47
19-21	45
22-24	43
25-35	42
36 plus	41

FLOATING BUILDING

Floating Building - A building unit that floats on water, is moored in a permanent location, and has a premises wiring system served through connection by permanent wiring to an electricity supply system not located on the premises.

Location of Service Equipment

- Shall be located adjacent to, but not in or on, the building or any floating structure.

Feeder Conductors

- Each floating building shall be supplied by a single set of feeder conductors from its service equipment.

MARINAS AND BOATYARDS

Marine Power Outlet - An enclosed assembly that can include receptacles, circuit breakers, fused switches, fuses, watt-hour meter(s), and monitoring means approved for marine use.

Distribution System - Yard and pier distribution systems shall not exceed 600 volts phase to phase

Electrical Connections - All electrical connections shall be located at least 300 mm above the deck of a floating pier. All electrical connections shall be located at least 300 mm above the deck of a fixed pier but not below the electrical datum plane.

Electrical Datum Plane

1. In land areas subject to tidal fluctuation, the electrical datum plane is a horizontal plane 600 mm above the highest tide level for the area occurring under normal circumstances, that is, highest high tide.
2. The electrical datum plane for floating piers and landing stages are the following:
 - a) Installed to permit rise and fall response to water level, without lateral movement.
 - b) A horizontal plane 800 mm above the water level at the floating pier or landing stage and a minimum of 300 mm above the level of the deck.

Number of Receptacles	Sum of the Rating of the Receptacles (percent)
1 – 4	100
5 – 8	90
9 – 14	80
15 – 30	70
31 – 40	60
41 – 50	50
51 – 70	40
71 – plus	30

CHAPTER 6 - SPECIAL EQUIPMENT

ELECTRIC SIGNS AND OUTLINE LIGHTINGS

Electric-Discharge Lighting - Utilizes fluorescent lamps, high intensity discharge lamps, or neon tubing.

Neon Tubing - Electric-discharge tubing manufactured into shapes that form letters, parts of letters, skeleton tubing, outline lighting, other decorative elements, or art forms, and filled with various inert gases.

Skeleton Tubing - Neon tubing that is itself the sign/outlines lighting and not attached to an enclosure.

Markings

- a) **Signs and Outline Lighting Systems** - shall be marked with the manufacturer's name, trademark, or other means of identification; and, input voltage and current rating.
- b) **With Incandescent Lamp Holders** - shall be marked to indicate the maximum allowable wattage of lamps. The markings shall be at least 6.00 mm high, and shall be visible during relamping.

Branch Circuit

- a) **Incandescent and Fluorescent Lamps** - Shall be rated not to exceed 20 amperes.
- b) **Neon Lamps** - Shall be rated not to exceed 30 amperes.

Disconnects

- a) Within the sight of the sign or outline lighting system that it controls.
- b) Within sight of the electronic or mechanical controllers located external to the sign.

Groundings

- Signs and metal equipment of outline lighting systems shall be grounded.

- a) **Flexible Metal Conduit** - Shall be permitted as a bonding means in lengths not exceeding 30 m.
- b) **Small Metal Parts** - The parts not exceeding 50 mm in any dimension, not likely to be energized and spaced at least 19 mm from neon tubing shall not require bonding.
- c) **Nonmetallic Conduit** - Shall be installed separate and remote, spaced at least 40 mm from the system for 100 Hz or less or 45 mm for systems 100 Hz and over.
- d) **Bonding Conductors** - Shall be made of copper and not smaller than 2.0 mm² (1.6 mm dia.).
- e) **Signs in Fountains** - Shall have all metal parts and equipment grounding conductors bonded.

Enclosure

- The enclosure shall be a sheet copper or aluminum at least 0.50 mm thick. Using of sheet steel for the enclosure shall be at least 0.40 mm thick.

Location

- a) **Vehicles** - Shall be least 4300 mm above areas with access to vehicles unless protected from damage
- b) **Pedestrians** - Neon tubing installed in pedestrians shall be protected from physical damage.
- c) **Adjacent to Combustible Materials** - The materials shall not be subjected to temperatures in excess of 90°C. The spacing between wood or other combustible materials shall not be less than 50 mm.
- d) **Wet Location** - Shall be listed watertight type or weatherproof and have drain holes.
 - Drain holes shall not be larger than 13 mm or smaller than 6.0 mm.
 - Every low point or isolated section of the equipment shall have at least 1 drain hole.

Ground-Fault Circuit Interrupter

- Shall be an integral part of the attachment plug or shall be located in the power-supply cord within 300 mm.

Ballast, Transformers, and Electronic Power Supplies

- a) **Accessibility** - Located where accessible and shall be securely fastened in place.
- b) **Wet Location** - Weatherproof type or of the outdoor type.
- c) **Working Space** - At least 900 mm high, 900mm wide, by 900 mm deep shall be provided.
- d) **Attic & Soffit Locations** - Permitted to be located provided there is an access door at least 900 mm by 600 mm of passageway with a walkway of 300 mm wide.

CRANES AND HOISTS

Contact Conductors

- a) **Locating or Guarding Contact Conductors** - The runway contact conductors shall be guarded, and bridge contact conductors shall be located or guarded in a manner that person cannot inadvertently touch energized current-carrying parts.
- b) **Contact Wires** - The extreme limit of displacement of the wire is within less than 40 mm
- c) **Supports along Runways** - Shall be supported at intervals not exceeding 6000 mm.
- d) **Supports on Bridges** - Bridge wire contact conductors shall be kept at least 65 mm apart, and, where the span exceeds 25 m, insulating saddles shall be placed at intervals not exceeding 15 m.
- e) **Supports for Rigid Conductors** - Shall be carried on insulating supports spaced at intervals of not more than 80 times the vertical dimension of the conductor, but in no case greater than 4 500 mm, and spaced apart sufficiently to give a clear electrical separation of conductors or adjacent collectors of not less than 25 mm.

Clearance

- Shall have a minimum of 750 mm to access to live parts where the controls are enclosed in cabinets, the door(s) shall either open at least 90 degrees or be removable.

Table 6.10.2.4(e) Demand Factors	
Number of Cranes or Hoists	Demand Factor
2	0.95
3	0.91
4	0.87
5	0.84
6	0.81
7	0.78

Table 6.10.2.4(a) Ampacities of Insulated Copper Conductors Used with Short-Time Rated Crane and Hoist Motors. Based on Ambient Temperature of 30°C. Up to Four Conductors in Raceway or Cable¹ Up to 3 ac² or 4 dc¹ Conductors in Raceway or Cable.						
Maximum Operating Temperature	75^oC		90^oC		125^oC	
Conductor Size [mm² (mm dia.)]	Types MTW, RH, RHW, THW, THWN, XHHW,		Types TA, TBS, SA, SIS, PFA, FEP, FEPB, RHH, THHN, XHHW, Z, ZW		Types FEP, FEPB, PFA, PFAH, SA, TFE, Z, ZW	
	60 Min	30 Min	60 Min	30 Min	60 Min	30 Min
1.25 (1.2)	8.5	10	—	—	—	—
2.0 (1.6)	24	25	29	30	36	38
3.5 (2.0)	32	35	38	43	48	53
5.5 (2.6)	42	45	51	54	63	68
8.0 (3.2)	52	57	60	65	69	76
14	80	91	87	100	107	126
22	104	120	115	135	138	163
30	118	138	128	150	154	185
38	125	153	138	168	184	222
50	172	210	191	234	229	275
60	196	236	217	260	268	327
80	260	316	283	345	344	420
100	282	347	300	376	424	522
125	360	415	395	456	504	628
150	460	588	452	643	594	745
200	520	665	574	735	718	910
250	661	848	726	916	898	1 145

AMPACITY CORRECTION FACTOR						
Ambient Temperature (°C)	For ambient temperature other than 30⁰C, multiply the ampacities shown above by the appropriate factor shown below.					
21-25	1.05	1.05	1.04	1.04	1.02	1.02
26-30	1.00	1.00	1.00	1.00	1.00	1.00
31-35	0.94	0.94	0.96	0.96	0.97	0.97
36-40	0.88	0.88	0.91	0.91	0.95	0.95
41-45	0.82	0.82	0.87	0.87	0.92	0.92
46-50	0.75	0.75	0.82	0.82	0.89	0.89
51-55	0.67	0.67	0.76	0.76	0.86	0.86
56-60	0.58	0.58	0.71	0.71	0.83	0.83
61-70	0.33	0.33	0.58	0.58	0.76	0.76
71-80	—	—	0.41	0.41	0.69	0.69
81-90	—	—	—	—	0.61	0.61
91-100	—	—	—	—	0.51	0.51
101-120	—	—	—	—	0.40	0.40

ELEVATORS

Number of Elevators on a Single Feeder	Demand Factor
1	1.00
2	0.95
3	0.90
4	0.85
5	0.82
6	0.79
7	0.77
8	0.75
9	0.73
10 or more	0.72

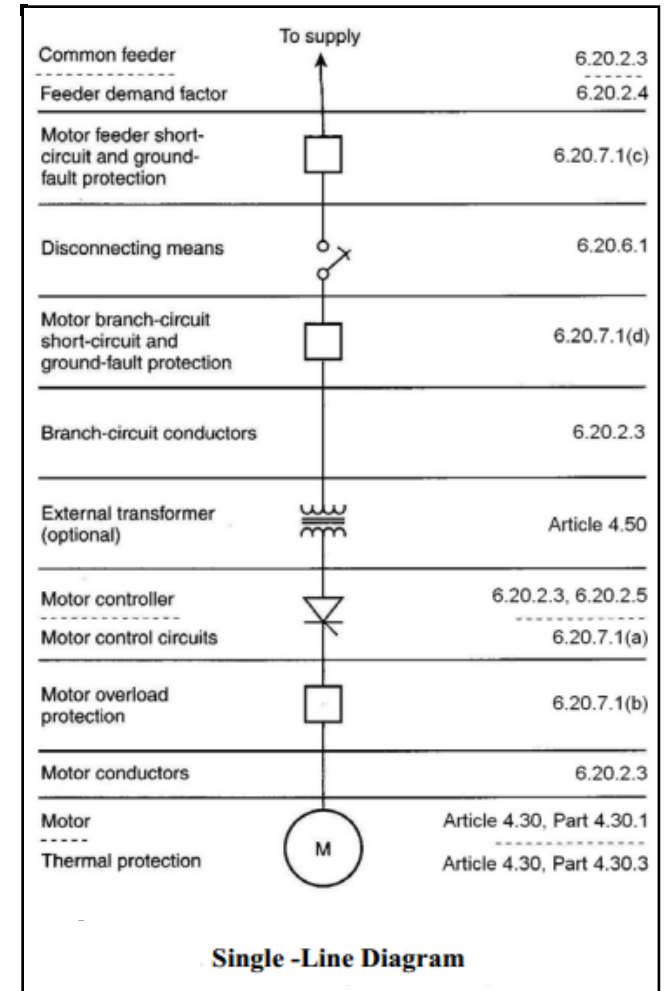
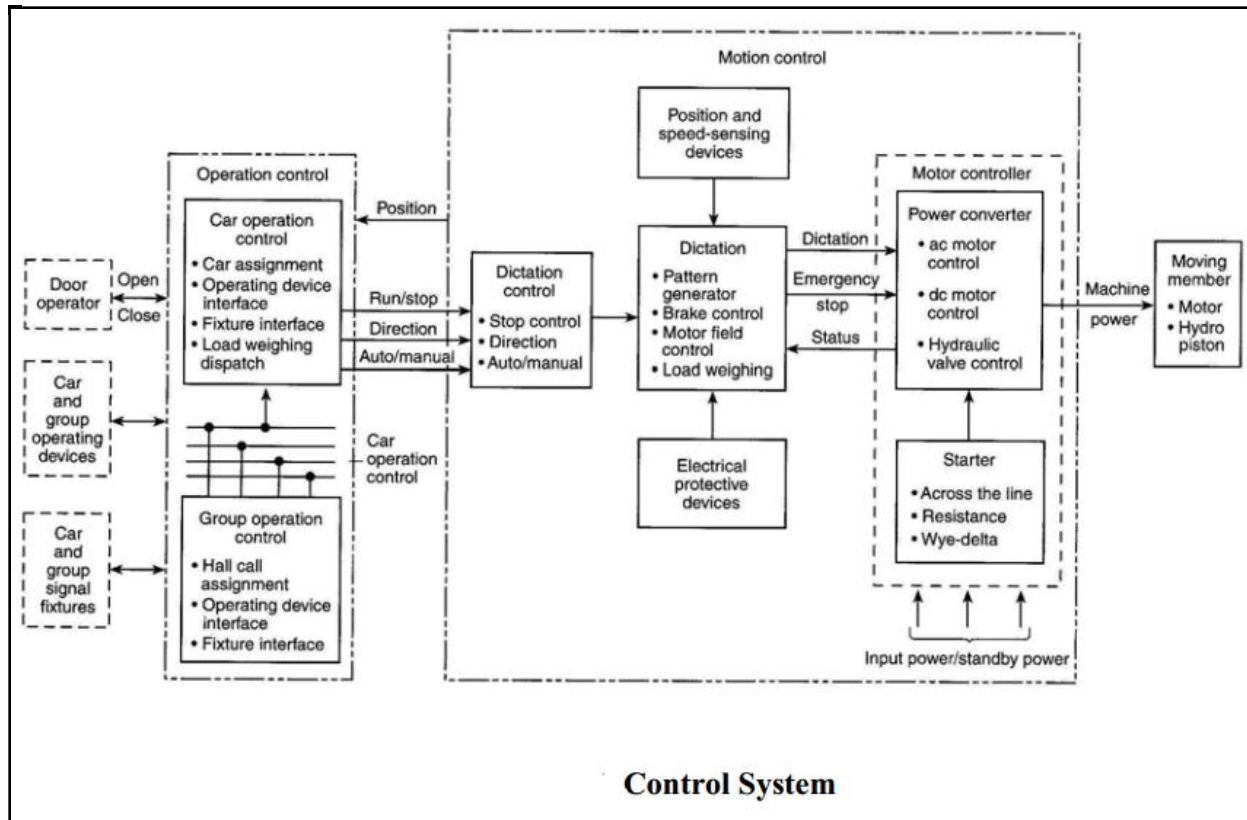

SWIMMING POOLS, FOUNTAINS, AND SIMILAR LOCATIONS

Dry-Niche Luminaire (Lighting Fixture) - A lighting fixture intended for installation in the wall of a pool or fountain in a niche that is sealed against the entry of pool water.

Wet-Niche Luminaire (Lighting Fixture) - A lighting fixture intended for installation in a forming shell mounted in a pool or fountain structure where the fixture will be completely surrounded by water.

Ground-Fault Circuit Interrupters (GFCI)

- Shall be self-contained units, circuit-breaker types, receptacle types, or other approved types.

Grounding

- The following equipment shall be grounded:

1. Through-wall lighting assemblies and underwater luminaries (lighting fixtures), other than those low-voltage systems listed for the application without a grounding conductor.
2. All electrical equipment located within 1 500 mm of the inside wall of the specified body of water.
3. All electrical equipment associated with the recirculation system of the specified body of water.
4. Junction boxes
5. Transformer enclosures
6. Ground-fault circuit interrupters
7. Panelboards that are not part of the service equipment and that supply any electrical equipment associated with the specified body of water.

Cord-and-Plug Connected Equipment

- a) Length - For other than storable pools, the flexible cord shall not exceed 900 mm in length.
- b) Equipment Grounding - flexible cord shall be made of copper not smaller than 3.5 mm².

Overhead Conductor Clearances

- a) **Communication Systems** - shall be permitted at a height of not less than 3000 mm above
- b) **Other Clearance Parameters:**

Table 6.80.1.8 Overhead Conductor Clearances			
Clearance Parameters	Insulated Supply or Service Drop Cables, 0 – 750 Volts to Ground, Supported on and Cabled Together with an Effectively Grounded Bare Messenger or Effectively Grounded Neutral Conductor	All Other Supply or Service-Drop Conductors Voltage to Ground	
		0 through 15 kV	Over 15 through 50 kV
A. Clearance in any direction to the water level, edge of water surface, base of diving platform, or permanently anchored raft	6 900 mm	7 500 mm	8 000 mm
B. Clearance in any direction to the diving platform or tower	4 400 mm	5 200 mm	5 500 mm
C. Horizontal limit of clearance measured from inside wall of the pool	This limit shall extend to the outer edge of the structures listed in A and B of this table but not to less than 3 000 mm		

Underground Wiring Locations

- Wirings shall not be permitted under the pool or within area extending 1500 mm horizontally from the inside wall of the pool unless the wiring is necessary for the pool equipment. Wirings shall be permitted only if installed in RMC, IMC, or a nonmetallic raceway which is corrosion resistant.

Wiring Method	Minimum Burial (mm)
Rigid metal conduit	150
Intermediate metal conduit	150
Nonmetallic raceways listed for direct burial without concrete encasement	450
Other approved raceways*	450

*Raceways approved for burial only where concrete encased shall require a concrete envelope not less than 50 mm thick.

Receptacles

- a) **Circulation and Sanitation System, Location** - Receptacles for water-pump motors or for other loads directly related to the circulation and sanitation system shall be located at least 3000 mm from the inside wall of the pool, or not less than 1500 mm if the conditions of the following are met:
 - 1. Consist of single receptacle
 - 2. Employ a locking configuration
 - 3. Are of the grounding type
 - 4. Have GFCI protection
- b) **Other Receptacles, Location** - Shall be not less than 3000 mm from the inside walls of the pool.
- c) **Dwelling Units** - A 230V 15 to 20-ampere receptacle on a general purpose shall be located not less than 3000 mm, and not more than 6000 mm. And, not more than 2000 mm above the floor, or grade level serving the pool.
- d) **GFCI Protection** - All 15 and 20 ampere, single-phase, 230V receptacles located within 6000 mm of the inside walls of a pool shall be of GFCI type. Also receptacles that supply pool pump motors and that are rated 15 or 20 amperes, 125 to 250 V, single phase.

Luminaires (Lighting Fixtures), Lighting Outlets, and Ceiling-Suspended (Paddle) Fans

- a) **New Outdoor Installation Clearances** - Shall be 1500 mm horizontally from the pool and of height not less than 3600 mm above the maximum water level of the pool.
- b) **Indoor Clearances** - Shall be protected by GFCI and of height not less than 2300 mm
 - 1. Totally enclosed luminaires (fixtures)
 - 2. Ceiling-suspended (paddle) fans identified for use beneath ceiling structures.
- c) **Existing Installations** - Luminaires located less than 1500 mm or less horizontally from the pool shall have a height of 1500 mm, rigidly attached, and GFCI protected.

Switching Devices

- Shall be located at least 1500 mm from the pool and separated by a solid fence, wall, or permanent barriers.

Junction Boxes and other Enclosures

- A junction box or an enclosure connected to a conduit, a transformer, a GFCI, or of similar device that extends directly to a forming shell or mounting bracket of a no-niche luminaire (fixture) shall meet the following requirements:

a) **Construction**

1. Be equipped with threaded entries or hubs or a nonmetallic hub.
2. Be comprised of copper, brass, suitable plastic or other approved corrosion resistant material.
3. Be provided with electrical continuity between every connected metal conduit and the grounding terminals by means of copper, brass, or other approved corrosion-resistant metal that is integral with the box.

b) **Installation**

1. **Vertical Spacing** - Shall be located not less than 100 mm, measured from the inside of the bottom of the box, above the ground level, or pool deck, or not less than 200 mm above the maximum pool water level, whichever provides the greater elevation.
2. **Horizontal Spacing** - The junction box shall be located not less than 1 200 mm from the inside wall of the pool, unless separated from the pool by a solid fence, wall, or other permanent barrier.
3. **Flush Deck Box** - If used on a lighting system operating at 15 volts or less, a flush deck box shall be permitted if both of the following apply:
 - An approved potting compound is used to fill the box to prevent moisture.
 - The flush deck box is located not less than 1 200 mm from the inside wall of the pool.

SOLAR PHOTOVOLTAIC SYSTEMS

Alternating-Current Photovoltaic Module - A complete, environmentally protected unit consisting of solar cells, optics, inverter, and other components, exclusive of tracker, designed to generate ac power when exposed to sunlight.

Array - A mechanically integrated assembly of modules or panels with a support structure and foundation, tracker, and other components, as required, to form a direct-current power-producing unit.

Bipolar Photovoltaic Array - A photovoltaic array that has two outputs, each having opposite polarity to a common reference point or center tap.

Blocking Diode - A diode used to block reverse flow of current into a photovoltaic source circuit.

Building Integrated Photovoltaics - Photovoltaic cells, devices, modules, or modular materials that are integrated into the outer surface/structure of a building and serve as the outer protective surface of that building.

Charge Controller - Equipment that controls dc voltage or dc current, or both, used to charge a battery

Diversion Charge Controller - Equipment that regulates the charging process of a battery by diverting power from energy storage to DC or AC loads or to an interconnected utility service.

Hybrid System - A system comprised of multiple power sources. These power sources may include photovoltaic, wind, micro-hydro generators, engine-driven generators, and others, but do not include electrical production and distribution network systems. Energy storage systems, such as batteries, do not constitute a power source for the purpose of this definition.

Interactive System - A solar photovoltaic system that operates in parallel with or may deliver power to an electrical production and distribution network. For the purpose of this definition, an energy storage subsystem of a solar photovoltaic system, such as a battery, is not another electrical production source.

Inverter - Equipment that is used to change voltage level or waveform, or both, of electrical energy [also known as a power conditioning unit (PCU) or power conversion system (PCS)] is a device that changes dc input to an ac output. Inverters may also function as battery chargers that use alternating current from another source and convert it into direct current for charging batteries.

Module - A complete, environmentally protected unit consisting of solar cells, optics, and other components, exclusive of tracker, designed to generate dc power when exposed to sunlight.

Panel - A collection of modules mechanically fastened together, wired, and designed to provide a field-installable unit.

Solar Cell - The basic photovoltaic device that generates electricity when exposed to light

Solar Photovoltaic System - The total components and subsystems that, in combination, convert solar energy into electrical energy suitable for connection to utilization load.

Stand-Alone System - A solar photovoltaic system that supplies power independently of an electrical production and distribution network.

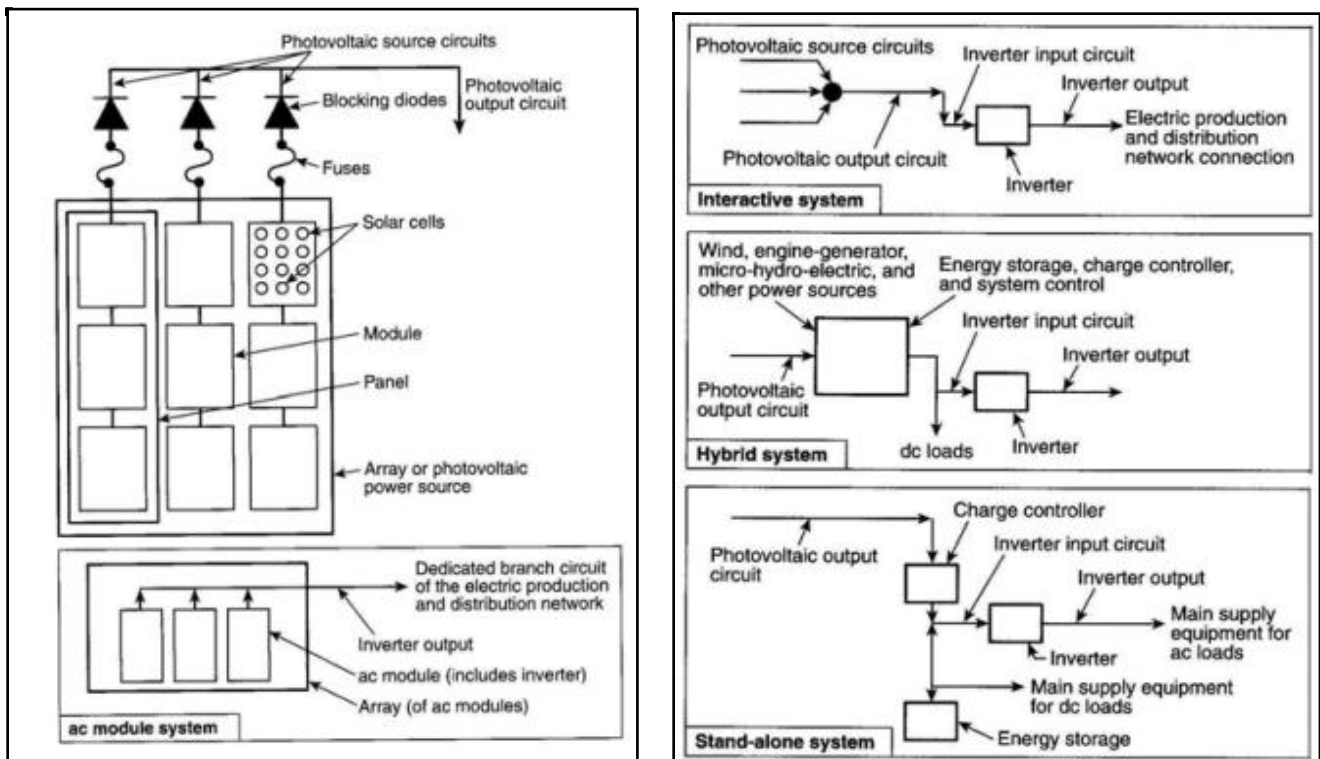

Ground-Fault Protection

- Roof-mounted dc photovoltaic arrays located on dwellings shall be provided with dc ground-fault protection to reduce fire hazards.

Unbalanced Interconnections

- a) **Single Phase** - Single-phase inverters for photovoltaic systems and ac modules in interactive solar photovoltaic systems shall not be connected to 3-phase power systems unless the interconnected system is designed so that significant unbalanced voltages cannot result.
- b) **Three Phase** - Three-phase inverters and 3-phase ac modules in interactive systems shall have all phases automatically de-energized upon loss of, or unbalanced, voltage in one or more phases unless the interconnected system is designed so that significant unbalanced voltages will not result.

Markings

- a) **Modules** - Shall be marked with identification of terminals or leads as to polarity, maximum overcurrent device rating for module protection, and with the following ratings:
 - 1. Open-circuit voltage
 - 2. Operating voltage
 - 3. Maximum permissible system voltage
 - 4. Operating current
 - 5. Short-circuit current
 - 6. Maximum power
- b) **Alternating-Current Photovoltaic Modules** - Shall be marked with identification of terminals or leads, and with identification of the following rating:
 - 1. Nominal operating ac voltage
 - 2. Nominal operating ac frequency
 - 3. Maximum ac power
 - 4. Maximum ac current
 - 5. Maximum overcurrent device rating for ac module protection
- c) **Direct-Current Photovoltaic Power Source** - Shall be provided by the installer at an accessible location at the disconnecting means for this power source:
 - 1. Operating current
 - 2. Operating voltage
 - 3. Maximum system voltage
 - 4. Short-circuit current

Storage Batteries

- a) **Operating Voltage (Dwelling Units)** - Shall have the cells connected to operate at less than 50 volts nominal. Lead-acid storage batteries shall have no more than twenty-four 2-volt cells connected in series (48-volts nominal)
- b) **Battery Nonconductive Cases and Conductive Cracks** - Flooded, vented, lead-acid batteries with more than twenty-four 2-volt cells connected in series (48 volts, nominal) shall not use conductive cases or shall not be installed in conductive cases. Conductive racks used to support the nonconductive cases shall be permitted where no rack material is located within 150 mm of the tops of the nonconductive cases.
- c) **Battery Systems of More Than 48 Volts** - The battery system shall be permitted to operate with ungrounded conductors, provided the following conditions are met:
 - 1. The dc and ac load circuits shall be solidly grounded.
 - 2. All main ungrounded battery input/output circuit conductors shall be provided with switched disconnects and overcurrent protection.
 - 3. A ground-fault detector and indicator shall be installed to monitor for ground faults in the battery bank.

Charge Control

- Shall be provided to control the charging process of the battery. Charge control is not required where the design of the photovoltaic source circuit is matched to the voltage rating and charge requirements of the interconnected batteries. Maximum charging current multiplied by 1 hour must be less than 3% of the rated battery capacity in ampere hour

CHAPTER 7 - SPECIAL CONDITIONS

EMERGENCY SYSTEMS

Test and Maintenance

- a) **Conduct or Witness Test** - The authority having jurisdiction shall conduct or witness a test of the complete system upon installation and periodically afterward.
- b) **Tested Periodically** - Systems shall be tested periodically on a schedule acceptable to the authority having jurisdiction to ensure the systems are maintained in proper operating condition.
- c) **Battery Systems Maintenance** - Where battery systems or unit equipments are involved, including batteries used for starting, control, or ignition in auxiliary engines, the authority having jurisdiction shall require periodic maintenance.
- d) **Written Record** - A written record shall be kept of such tests and maintenance.
- e) **Testing Under Load**- Means for testing all emergency lighting and power systems during maximum anticipated load conditions shall be provided.

Circuit Wiring

- a) **Wiring**- Two or more emergency circuits supplied by the same source shall be permitted in the same raceway, cable, box, or cabinet. Wiring from an emergency source or emergency source shall be kept entirely independent of all other wiring unless permitted in the ff:
 1. Wiring from the normal power source located in transfer equipment enclosure.
 2. Wiring supplied from 2-sources in exit or emergency luminaires.
 3. Wiring from 2-sources in a common junction box for emergency luminaires.
 4. Wiring containing only the branch circuit supplying a single unit equipment.
- b) **Wiring Design and Location** - Shall be designed and located so as to minimize the hazards that might cause failure due to flooding, fire, icing, vandalism, and other adverse conditions.
- c) **Fire Protection** - Listed are the additional requirements for buildings with 1000 persons or more or in buildings above 23 m in height with the following occupancies: assembly, educational, residential, detention and correctional, business, and mercantile.
 - **Feeder Circuit Wiring** - Shall meet one of the following conditions:
 1. Be installed in spaces/areas that are fully protected and with an approved automatic fire suppression system.
 2. Listed electrical circuit protective system with minimum of 1-hour fire rating.
 3. Protected by a listed thermal barrier system for the electrical system components.
 4. Protected by a fire-rated assembly listed to achieve a fire rating of 1-hour.
 5. Be embedded in not less than 50 mm concrete.
 6. Is a cable listed to maintain circuit integrity for not less than 1 hour.

Sources of Power

- a) **Storage Battery** - Shall be of suitable rating and capacity to supply and maintain the load for a minimum period of 1 ½ hours, without the voltage to the load falling 87 ½ of the normal.
- b) **Generator Set**
 1. **Prime Mover-Driven**- A time-delay feature permitting a 15-minute setting shall be provided to avoid retransfer in case of short-time reestablishment of the normal source.
 2. **Internal Combustion as Prime Mover** - An on-site fuel supply shall be provided sufficient for not less than 2 hours' full demand operation of the system.
 3. **Battery Power and Dampers** - Battery shall be equipped with an automatic charging means independent of the generator set. And, the damper used for ventilation of the genset must also be connected to the emergency system
 4. **Auxiliary Power Supply** - Generator sets that require more than 10 seconds to develop power shall be permitted if an auxiliary power supply energizes the emergency system until the generator can pick up the load.

5. **Outdoor Generator Sets** - An additional disconnecting means is not required in the building or structure it supplies if it has a disconnecting means within sight or located in the house of the genset.
- c) **Separate Service** - Where acceptable to AHJ as suitable for emergency source additional service is permitted provided it has a separate service drop or service lateral. And, service conductors sufficiently remote electrically and physically from any other service conductors.
- d) **Unit Equipment** - Shall be provided illumination consisting of the following:
 1. A rechargeable battery
 2. A battery charging means
 3. One or more lamps mounted on the equipment.
 4. A relaying device arranged to energize the lamps automatically upon failure of equipment.

Ground-Fault Protection of Equipment

- The alternate source for emergency systems shall not be required to have ground-fault protection of equipment with automatic disconnecting means.

LEGALLY REQUIRED STANDBY SYSTEMS

Legally Required Standby Systems - Systems required and so classed as legally required standby by municipal, state, federal, or other codes or by any governmental agency having jurisdiction. These systems are intended to automatically supply power to selected loads (other than those classed as emergency systems) in the event of failure of the normal source.

Circuit Wiring

- The legally required standby stem wiring shall be permitted to occupy the same raceways, cables, boxes, and cabinets with other general wiring.

Sources of Power for Legally Required Standby Systems

- Shall be available within the time required for the application but not to exceed 60 seconds.

Same Provisions with Emergency Systems for Storage Battery, Generator Set, Separate Service and Unit Equipment

Ground-Fault Protection of Equipment

- The alternate source for legally required standby systems shall not be required to have ground-fault protection of equipment.

OPTIONAL STANDBY SYSTEMS

Optional Standby Systems - Those systems intended to supply power to public or private facilities or property where life safety does not depend on the performance of the system. Optional standby systems are intended to supply on-site generated power to selected loads either automatically or manually.

Circuit Wiring

- The optional standby stem wiring shall be permitted to occupy the same raceways, cables, boxes, and cabinets with other general wiring

Outdoor Generator Sets

- An additional disconnecting means is not required in the building or structure it supplies if it has a disconnecting means within sight or located in the house of the genset.

CHAPTER 8 - COMMUNICATION SYSTEMS

COMMUNICATION CIRCUITS

Wires and Cables Outside of the Building (Clearance):

- a) **On Poles and In-Span** - Supply service drops of 0-750 volts running above and parallel to communications service drops shall have a minimum separation of 300 mm at any point in the span, including the point of and at their attachment to the building.
- b) **Above Roofs** - Shall have a vertical clearance of not less than 2500 mm from all points of the roof which they pass.
- c) **Lighting Conductors** - A separation of at least 1800 mm shall be between communications wires and cables on buildings and lightning conductors.

RADIO AND TELEVISION EQUIPMENT

Clearances - Receiving Stations

- a) **Outside of Buildings** - Lead-in conductors attached to buildings shall be installed so that they cannot swing closer than 600 mm to the conductors of circuits of 250V or less between conductors, or 3000 mm to the conductors of circuits of over 250V between conductors, except that in the case of circuits not over 150V between conductors, where all conductors involved are supported so as to ensure permanent separation, the clearance shall be permitted to be reduced but shall not be less than 100 mm.
- b) **From Lighting Rod Systems** - The clearance shall not be less than 1800 mm
- c) **Underground Conductors** - Shall be separated at least 300 mm from conductors of any light or power circuits or Class 1 circuits.
- d) **Antennas and Lead-ins (Indoors)** - Shall not be run nearer than 50 mm to conductors of other wiring systems in the premises.

APPENDIX

NEMA Type	Definition
1	General-purpose. Protects against dust, light, and indirect splashing but is not dust-tight; primarily prevents contact with live parts; used indoors and under normal atmospheric conditions.
2	Drip-tight. Similar to Type 1 but with addition of drip shields; used where condensation may be severe (as in cooling and laundry rooms).
3, 3S, 3X	Weather-resistant. Protects against weather hazards such as rain and sleet; used outdoors on ship docks, in construction work, and in tunnels and subways. 3X includes corrosions.
3R	Intended for outdoor use. Provides a degree of protection against falling rain and ice formation. Meets rod entry, rain, external icing, and rust-resistance design tests.
4 and 4X	Watertight (weatherproof). Must exclude at least 65 GPM of water from 1-in. nozzle delivered from a distance not less than 10 ft for 5 min. Used outdoors on ship docks, in dairies, and in breweries. The 4X model has corrosion resistance.
5	Dust-tight. Provided with gaskets or equivalent to exclude dust; used in steel mills and cement plants.
6 and 6P	Submersible. Design depends on specified conditions of pressure and time; submersible in water or oil; used in quarries, mines, and manholes.
7	Hazardous. For indoor use in Class I, Groups A, B, C, and D environments as defined in the NEC.
8	Hazardous. For indoor and outdoor use in locations classified as Class I, Groups A, B, C, and D as defined in the NEC.
9	Hazardous. For indoor and outdoor use in locations classified as Class II, Groups E, F, or G as defined in the NEC.
10	MSHA. Meets the requirements of the Mine Safety and Health Administration, 30 CFR Part 18 (1978).
11	General-purpose. Protects against the corrosive effects of liquids and gases. Meets drip and corrosion-resistance tests.
12 & 12K	General-purpose. Intended for indoor use, provides some protection against dust, falling dirt, and dripping noncorrosive liquids. Meets drip, dust, and rust resistance tests.
13	General-purpose. Primarily used to provide protection against dust, spraying of water and noncorrosive coolants. Meets oil exclusion and rust resistance design tests.

Standard FLC of Single-Phase AC Motors				
HP	115 V	200 V	208 V	230 V
1/6	4.4	2.5	2.4	2.2
1/4	5.8	3.3	3.2	2.9
1/3	7.2	4.1	4.0	3.6
1/2	9.8	5.6	5.4	4.9
3/4	13.8	7.9	7.6	6.9
1	16	9.2	8.8	8
1.5	20	11.5	11	10
2	24	13.8	13.2	12
3	34	19.6	18.7	17
5	56	32.2	30.8	28
7.5	80	46	44	40
10	100	57.5	55	50

Standard FLC of 3-Phase Synchronous Motors (Unity Power Factor)				
HP	230 V	460 V	575 V	2300 V
25	53	26	21	
30	63	32	26	
40	83	41	33	
50	104	52	42	
60	123	61	49	12
75	155	78	62	15
100	202	101	81	20
125	253	126	101	25
150	302	151	121	30
200	400	201	161	40

Note: For 90% and 80% power factors, the figures shall be multiplied by 1.1 and 1.25 respectively.

Standard FLC of 3-Phase Induction Motors							
HP	115 V	200 V	208 V	230 V	460 V	575 V	2300 V
1/2	4	2.3	2.2	2	1	0.8	
3/4	5.6	3.2	3.1	2.8	1.4	1.1	
1	7.2	4.1	4.0	3.6	1.8	1.4	
1.5	10.4	6.0	5.7	5.2	2.6	2.1	
2	13.6	7.8	7.5	6.8	3.4	2.7	
3		11.0	10.6	9.6	4.8	3.9	
5		17.5	16.7	15.2	7.6	6.1	
7.5		25.3	24.2	22	11	9	
10		32.2	30.8	28	14	11	
15		48.3	46.2	42	21	17	
20		62.1	59.4	54	27	22	
25		78.2	74.8	68	34	27	
30		92	88	80	40	32	
40		119.6	114.4	104	52	41	
50		149.5	143	130	65	52	
60		177.1	169.4	154	77	62	16
75		220.8	211.2	192	96	77	20
100		285.2	272.8	248	124	99	26
125		358.8	343.2	312	156	125	31
150		414	396	360	180	144	37
200		552	528	480	240	192	49

Standard FLC of Single-Phase AC Motors						
HP	90 V	120 V	180 V	240 V	500 V	550 V
1/4	4.0	3.1	2.0	1.6		
1/3	5.2	4.1	2.6	2.0		
1/2	6.8	5.4	3.4	2.7		
3/4	9.6	7.6	4.8	3.8		
1	12.2	9.5	6.1	4.7		
1.5		13.2	8.3	6.6		
2		17	10.8	8.5		
3		25	16	12.2		
5		40	27	20		
7.5		58		29	13.6	12.2
10		76		38	16	16
15				55	27	24
20				72	34	31
25				89	43	38
30				106	51	46
40				140	67	61
50				173	83	75
60				206	99	90
75				255	123	111
100				341	164	148
125				425	205	185
150				506	246	222
200				675	330	294

Standard FLC of Single-Phase Transformers				
KVA	120 V	240 V	480 V	600 V
1	8.33	4.17	2.08	1.67
1/2	12.5	6.25	3.13	2.5
2	16.7	8.33	4.17	3.33
3	25	12.5	6.25	5
5	41.7	20.8	10.4	8.33
7.5	62.5	31.3	15.6	12.5
10	83.3	41.7	20.8	16.7
15	125	62.5	31.3	25
20	167	83.3	41.7	33.3
25	208	104	52.1	41.7
30	250	125	62.5	50
37.5	313	156	78	62.5
50	417	208	104	83.3
75	625	313	156	125
100	833	417	208	167
150	1250	625	313	250
167	1392	696	348	278
200	1667	833	417	333
250	2083	1042	521	417
333	2775	1388	694	555
500	4167	2083	1042	833

Standard FLC of Three-Phase Transformers				
KVA	208 V	240 V	480 V	600 V
3	8.3	7.2	3.6	2.9
6	16.6	14.44	7.2	5.8
9	25	21.6	10.8	8.7
15	41.6	36	18	14.4
20	55.6	48.2	24.1	19.3
25	69.5	60.2	30.1	24.1
30	83	72	36	28.8
37.5	104	90.3	45.2	36.1
45	125	108	54	43
50	139	120	60.2	48.2
60	167	145	72.3	57.8
75	208	180	90	72
100	278	241	120	96.3
112.5	312	270	135	108
150	415	360	180	144
200	554	480	240	192
225	625	540	270	216
300	830	720	360	288
400	1110	960	480	384
500	1380	1200	600	480
750	2080	1800	900	720
1000	2780	2400	1200	960
1500	4150	3600	1800	1440
2000	5540	4800	2400	1920

Standard Rating of Disconnects (Amperes)			
30	200	800	1600
60	400	1000	1800
100	600	1200	

Standard Rating of Switchboards or Switchgears

Single-Phase				
200	600	1200	2000	3000
400	800	1600	2500	4000

Three-Phase				
400	800	1600	2500	4000
600	1200	2000	3000	

Standard Rating of Fuses and CB's (Amperes)

15	70	225	800
20	80	250	1000
25	90	300	1200
30	100	350	1600
35	110	400	2000
40	125	450	2500
45	150	500	3000
50	175	600	4000
60	200	700	5000
			6000

For fuses only, additional standard sizes are 1, 3, 6 and 10.

Standard Rating of Busways or Busducts (Amperes)

Single-Phase and Three-Phase						
225	600	1000	1350	2000	3000	5000
400	800	1200	1600	2500	4000	

Standard Sizes of Gutters and Wireways

2 1/2" x 2 1/2"	6" x 8"	10" x 10"
4" x 4"	8" x 8"	

These are available in 12", 24", 36", 48" and 60" lengths

Standard Sizes of Pull Boxes and Junction Boxes

4" x 4" x 4"	10" x 8" x 4"	12" x 12" x 6"
6" x 4" x 4"	10" x 8" x 6"	12" x 12" x 8"
6" x 6" x 4"	10" x 10" x 4"	15" x 12" x 4"
6" x 6" x 6"	10" x 10" x 6"	15" x 12" x 6"
8" x 6" x 4"	10" x 10" x 8"	18" x 12" x 4"
8" x 6" x 6"	12" x 8" x 4"	18" x 12" x 6"
8" x 6" x 8"	12" x 8" x 6"	18" x 18" x 4"
8" x 8" x 4"	12" x 10" x 4"	18" x 18" x 6"
8" x 8" x 6"	12" x 10" x 6"	24" x 18" x 6"
8" x 8" x 8"	12" x 12" x 4"	24" x 24" x 6"
		24" x 24" x 8"

Wires and Conduits

Trade Name	Type Letter	Operating Temperature
FEP	- Fluorinated ethylene propylene	90°C/200°C
FEPB	- Fluorinated ethylene propylene	90°C/200°C
MI	- Mineral insulation (metal sheathed)	90°C/250°C
MTW	- Moisture-, heat-, and oil-resistant thermoplastic	60°C/90°C
PFA	- Perfluoro-alkoxy	90°C/200°C
PFAH	- Perfluoro-alkoxy	250°C
RHH	- Thermoset	90°C
RHW	- Moisture-resistant thermoset	75°C
RHW-2	- Moisture-resistant thermoset	90°C
SA	- Silicone	90°C/200°C
SIS	- Thermoset	90°C
TBS	- Thermoplastic and fibrous outer braid	90°C
TFE	- Extended polytetra-fluoro ethylene	250°C
THHN	- Heat-resistant thermoplastic	90°C
THHW	- Moisture- and heat-resistant thermoplastic	75°C/90°C
THW	- Moisture- and heat-resistant thermoplastic	75°C/90°C
THWN	- Moisture- and heat resistant thermoplastic	75°C
TW	- Moisture-resistant thermoplastic	60°C
UF	- Underground feeder and branch-circuit cable	60°C/75°C
USE	- Underground service-entrance cable	75°C
XHH	- Thermoset	90°C
XHHW	- Moisture-resistant thermoset	75°C/90°C
XHHW-2	- Moisture-resistant thermoset	90°C
Z	- Modified ethylene tetrafluoro-ethylene	90°C/150°C
ZW	- Modified ethylene tetrafluoro-ethylene	75°C/90°C/200°C

AC	- Armored cable
EMT	- Electrical metallic tubing
ENT	- Electrical nonmetallic tubing
FCC	- Flat conductor cable
FMC	- Flexible metal conduit
FMT	- Flexible metallic tubing
HDPE	- High density polyethylene conduit
IGS	- Integrated gas spacer
IMC	- Intermediate metal conduit
LFMC	- Liquidtight flexible metal conduit
LFNC	- Liquidtight flexible nonmetallic conduit
MC	- Metal-clad cable
MV	- Medium voltage cable
NM/NMC/NMC	- Nonmetallic sheathed cable
NUCC	- Nonmetallic underground conduit with conductors
RMC	- Rigid metal conduit
RNC	- Rigid nonmetallic conduit
TC	- Power and control tray cable